



Model	Description	Voltage	Kvs
2 way			
VS21	motorized valve 1/2" n.c.	230V - 50/60HZ	2,2
VS22	motorized valve 3/4" n.c.	230V - 50/60HZ	3,0
VS23	motorized valve 1" n.c.	230V - 50/60HZ	6,9
VS41	motorized valve 1/2" n.c.	24V - 50/60HZ	2,2
VS42	motorized valve 3/4" n.c.	24V - 50/60HZ	3,0
VS43	motorized valve 1" n.c.	24V - 50/60HZ	6,9
3 way			
VD21	motorized valve 1/2" n.c.	230V - 50/60HZ	2,6
VD22	motorized valve 3/4" n.c.	230V - 50/60HZ	3,4
VD23	motorized valve 1" n.c.	230V - 50/60HZ	6,5
VD41	motorized valve 1/2" n.c.	24V - 50/60HZ	2,6
VD42	motorized valve 3/4" n.c.	24V - 50/60HZ	3,4
VD43	motorized valve 1" n.c.	24V - 50/60HZ	6,5



## APPLICATION AND USE

The VS/VD Series Valve accurately control the flow of chilled water and hot water through coils and heat exchanges of all types, in a wide range of Heating, Ventilating and Air Conditioning (HVAC) applications. Each zone valve is operated by a hysteresis synchronous motor for long life. When the thermostat is satisfied, a spring returns the valve to its normal position. The actuator can be removed from the valve body quickly and easily, simplifying installation and servicing. No special linkage kit or commissioning is required.

## GENERAL CHARACTERISTICS

- Direct replacement for all existing two-position applications.
- Hysteresis synchronous motor for long life.
- Spring return operation provides a fail-safe.
- Actuator mounts directly onto valve body without need for linkages or calibration.
- Manual override lever.
- Valves and actuators are maintenance-free
- Actuator can be replaced without any tools, or removal of valve from system.

## MANUFACTURING CHARACTERISTICS

Body:	Forged Brass
Stem:	Chrome Plated Brass
Seat:	Brass
Paddle:	BUNA-N
Actuator:	Stainless Steel Base Aluminium Cover

## TECHNICAL CHARACTERISTICS

Operating pressure:	300 psi
Pipe connection:	BSP Female Thread
Leakage:	ANSI class IV (0,01%)
Temperature limits:	
• fluid	93°C
• working	40°C
• storage	from -40 to 71°C
Humidity:	from 5 to 95% R.H., non condensing
Allowed fluids:	Hot and chilled water with up to 50% glycol
Timing:	30s max for 50Hz 20s max spring return
Close-off:	Refer to the following table

Valve type	DN	Close off ΔP kPa
2-way	1/2"	414
	3/4"	310
	1"	208
3-way	1/2"	380
	3/4"	276
	1"	173

Motor voltage:	Refer to model selection table
Power requirements:	5W - 6,8VA
Control signal:	On/off, 2 position, spring return
Weight:	1,40kg (valve+actuator)
Agency approval:	CE compliant

## OPERATION

The VS/VD are two position spring return valves. When powered, the actuator moves to the desired position, tensing the spring return system. When power is removed the actuator returns to the normal position. Two position spring return valves are equipped with an optional built-in auxiliary SPDT end switch for interfacing or signalling; for example, zone pump burner control.

## INSTALLATION

Use a 25 to 40mm wrench (not provided). Installer must be a qualified, experienced technician

### PRECAUTIONS

- Electrical shock hazard! Disconnect power before installation to prevent electrical shock or equipment damage.
- Make all connections in accordance with the electrical wiring diagram and in accordance with national and local electrical codes. Use copper conductors only.
- All conductors shall be provided with insulation rated for the highest voltage for motor and end switch circuits.
- Avoid locations where excessive moisture, corrosive fumes, explosive vapours or vibration are present.
- Avoid electrical noise interference. Do not install near large conductors, electrical machinery or welding equipment.
- When making lead connections within the actuator, use caution not to put leads of connectors underneath the motor.

### MOUNTING

The valves can be mounted in horizontal or vertical piping. When installed in horizontal piping, the actuator must be above the valve body. When installed in horizontal piping the actuator can be tilted left or right but it must not be tilted below 85° from vertical. Refer to the figure below.

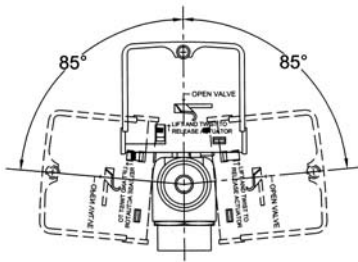

### NOTES

- Make certain there is no overhead water source that may drip onto valve actuator.
- In normal service, some condensation may occur on or around the valve. A drip pan may be necessary or the valve body may be insulated.

### PIPING

The valves must be piped so that the paddle always closes against the direction of flow, except in diverting configurations (refer to piping schemes). The manual operating lever can be used to allow flushing of the hydronic system after installation. Owing to condensation in chilled water applications, install the valve over a drip pan. Zone valves are designed for use in closed hydronic heating and cooling systems. Use in systems which have substantial make-up water (open systems) is not recommended. High levels of dissolved oxygen and chlorine found in open systems may attack the valve materials and result in premature failure.

#### Manual Operating Lever

Move the manual operating lever slowly to the open position and hold in the retaining notch until the gear is taken up by the return spring. When valves are placed in the open position with the manual operating lever, the paddle is removed from the seat or port.

The manual operating lever will reset to the automatic position when the valve is cycled electrically the first time.

### NOTES

- 3 way valves are always closed at B Port when no power is applied to the motor.
- On power-up, the valve closes to A Port on 3 way valves.
- Orient the 3 way valve body as needed for normally-open or normally-closed flow through coil.

Apply Teflon tape to all but the last two threads of male pipe thread. Hand screw the pipe into the valve, turning it as far as it will go. Use a wrench to fully tighten the valve to the pipe. Do not over tighten or strip threads.

### INSTALLING ACTUATOR ON VALVE BODY

Align the body with the actuator to ensure the valve stem is inserted into the large mating hole and the latching post on the body is inserted into the elliptic mating hole, both holes being on the bottom side of the actuator. Turn the actuator fully counter-clockwise to engage the actuator on the body.

### PIPING SCHEMES

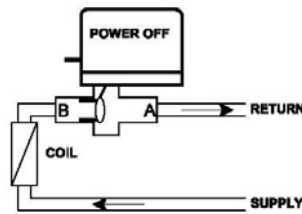

2 way valve normally closed to the coil

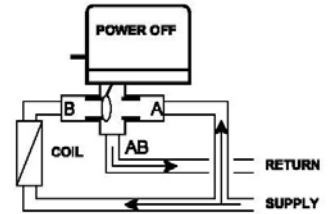

3 way valve in mixing configuration normally closed to the coil

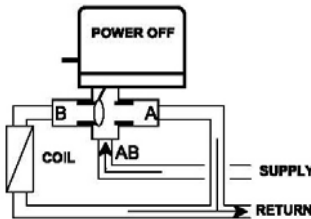

3 way valve in diverting configuration normally closed to the coil

### WIRING DIAGRAM

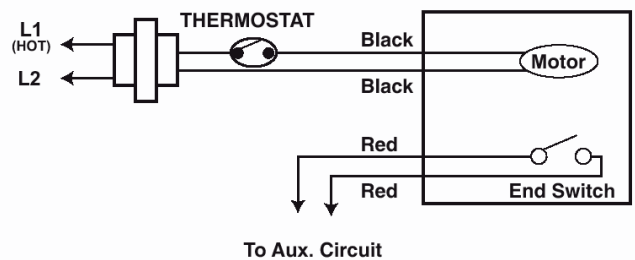

### COMMISSIONING

- Make sure the valve stem rotates freely before and after installing the actuator.
- If the stem does not operate freely it may indicate that the stem was damaged and may require that the valve be repaired or replaced.
- After the piping is under pressure, check the valve body and the connections for leaks.
- After the valve and actuator are installed, power the actuator and check the operation.

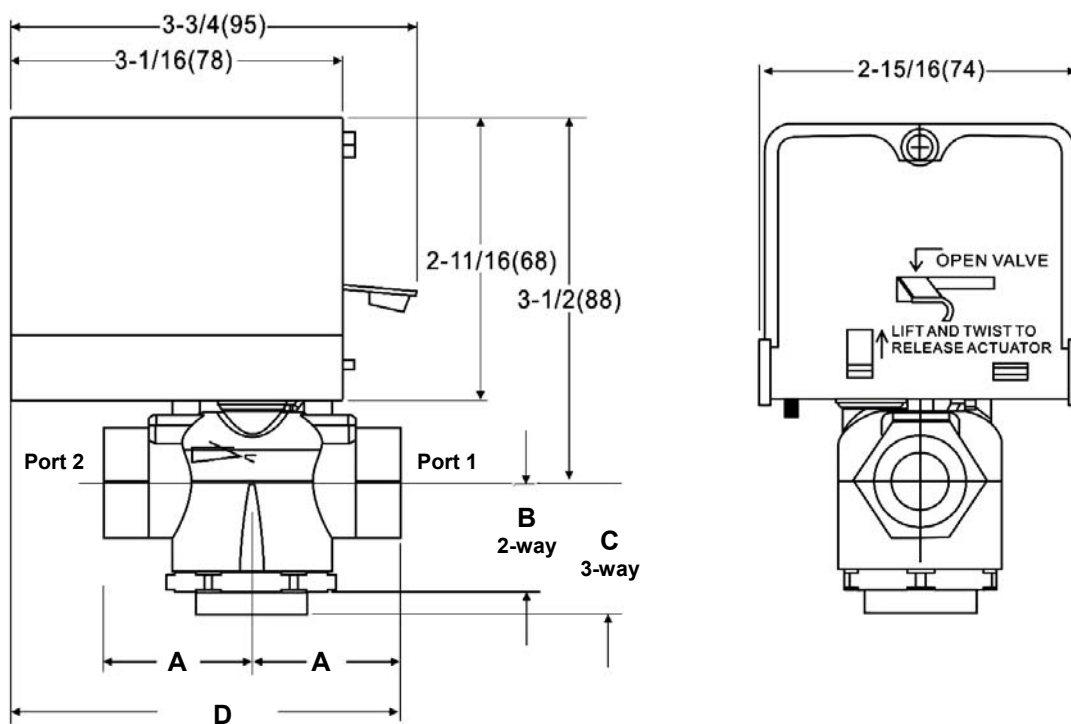

DN	A	B	C	D	E	F
1/2"	35	24	38	92	66	84
3/4"	40	24	38	95	68	88
1"	44	25	43	100	68	88