

User's Manual

W500T2/W500T2MB



TABLE OF CONTENTS

INTRODUCTION	3
USER INTERFACE.....	4
FUNCTION DESCRIPTION	5
GENERAL.....	5
FOR THE 2 ANALOGUE OUTPUTS CAN BE SELECTED:.....	5
FOR THE 2 ON/OFF DIGITAL RELAY OUTPUTS CAN BE SELECTED:.....	6
MINIMUM AND/OR MAXIMUM LIMITS	8
OPERATING MODE.....	10
MANUAL OVERRIDE KEY FOR THE OPERATING MODE	10
CLOCK ENABLE WITH INDEPENDENT TIME SCHEDULE	11
OUTSIDE DIGITAL ENABLE	11
FACTORY DATA LOAD	12
STORING DATA IN PERMANENT MEMORY	12
LOADING DATA FROM PERMANENT MEMORY	12
REMOTE SET	12
OUTSIDE SENSOR FROM SUPERVISION FOR COMPENSATION	12
LINK BUS COMMUNICATION	12
MODBUS COMMUNICATION.....	14
ERROR SIGNALLING.....	14
FRONT PANEL AND DATA ACCESS MENU.....	15
PARAMETER CONFIGURATION MENU.....	16
Level 1 Parameter selection Parameter modification	16
Parameters - Mode A1	16
Parameters - Mode A2.....	16
Parameters - Mode A2.....	17
Parameters - Mode A3 / Mode A4.....	17
Parameters - Mode D1.....	18
Parameters - Mode D2.....	19
Parameters - Mode D3.....	19
Parameters - Mode D4.....	19
PROGRAMME MENU FOR OPERATING MODES AND TIME SCHEDULES	20
Output override setting	21
Settings - 0-10Volt Analogue Outputs (PA1 and PA2).....	21
Settings - 0-10Volt Analogue Outputs (PA1 and PA2).....	22
Settings - Relay Digital Outputs (Pd1 and Pd2) – Operating Modes 1, 2 and 3	22
Setting - Relay digital Outputs (Pd1 and Pd2) – Operating Mode 4	22
MENU DIAGRAM	23
CONTROL PARAMETER TABLES (LEVEL 1).....	24
TABLES OF OPERATING MODES AND TIME SCHEDULES (LEVEL 2)	25
SYSTEM APPLICATIONS.....	28

INTRODUCTION

The controller is provided with four control Loops, independent two by two, two Analogue Loops and two on/off Hysteresis Loops.

Each Analogue Loop is connected to a 0-10 Vdc output.

Each on/off hysteresis is linked to a relay output with exchange contact. All Loops have independent control parameters and set point.

All the four Loops share the SC/SL sensor (configurable like Compensation or Limit sensor). The Analogue Loop 1 and Digital 1 use the SR1 control sensor and they are independent from Analogue Loop 2 and Digital 2 which use the SR2 control sensor. The autonomy among the Loops involves also the time schedule with two weekly programs and the daily program. To activate the Loop, the SR1 and/or SR2 sensors must be present while the SC/SL sensor cannot be. It is possible to enable its functions, if it is present.

The device is also equipped with two dry-contact digital inputs, which can be used for outside enable or summer/winter changeover functions.

The device is characterized by a user interface composed of a 3 ½-digit FND display, five buttons and of twelve LEDs located on the front membrane. The information displayed on screen depends on whether the sensors are present or not and on the related function enable.

The controller is also provided with a two-wire local bus called Link Bus. Through the local bus port it is possible to connect up to 4 different devices (1 Master + 3 Slave) with the purpose to share the three Sensors and the operating mode with other devices of the same line. The local bus also allows the W500T2 to be supervised, if at least one W500T2MB is connected.

The W500T2MB version distinguishes from the basic W500T2 for its on-board RS485-ModBus communication interface and for the Real Time Clock with daily and weekly schedules.

The W500T2MB allows supervision also for other W500T2 devices (max. n. 3) connected to it through a Link Bus and the set time schedules can be shared.

W500T2 controllers (Slave), if configured properly (Abo=On), share the PS1 weekly program and the P1 daily program.

Electrical connections:

1	GND	13	230 Vac F
2	SR1	14	230 Vac N
3	SC/SL	15	Rel 1 CO
4	SR2	16	Rel 1 NA
5	GND	17	Rel 1 NC
6	Di1	18	Rel 2 CO
7	Di2	19	Rel 2 NA
8	Link Bus +	20	Rel 2 NC
9	Link Bus -	22	Ao1
10	Bus 485 +	23	GND
11	Bus 485 -	24	Ao2
12	GND 485		

} W500T2MB only

Legend:

- SR1: Ao1 Do1 Control sensor
- SC/SL: Limit/Compensation sensor
- SR2: Ao2 Do2 Control sensor
- U1: User 1 (e.g. fan or damper)
- U2: User 2 (e.g. on/off valve or circulation pump)
- S1: Proportional actuator 0 – 10 Volt
- S2: Proportional actuator 0 – 10 Volt

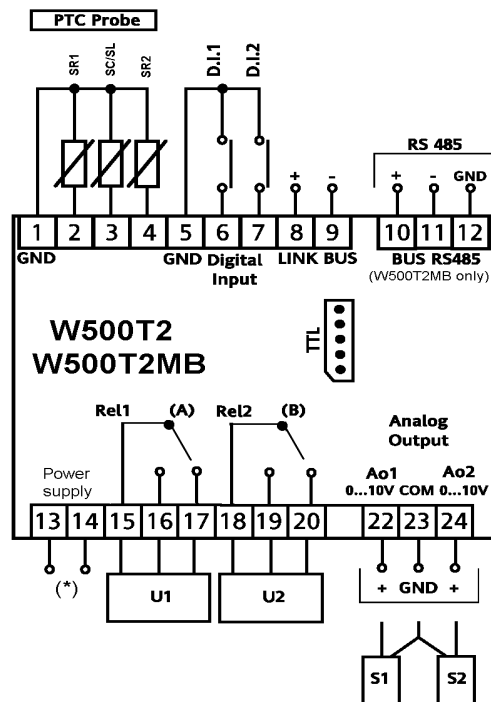
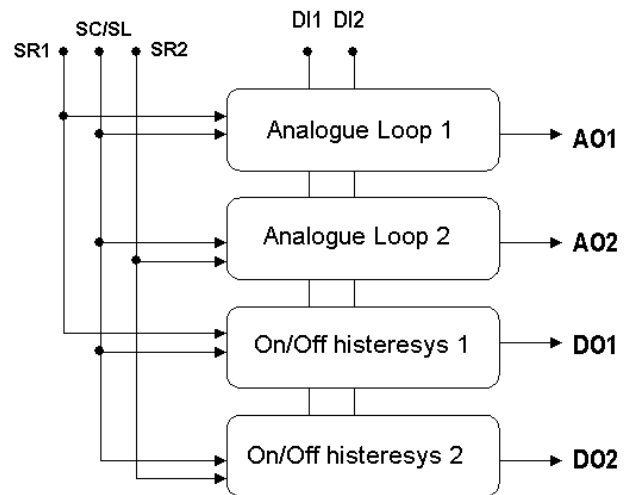



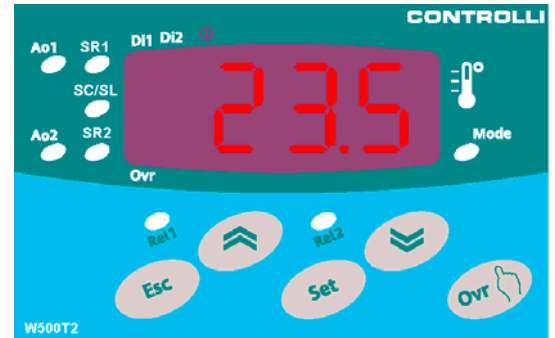

USER INTERFACE

The device is characterised by a user interface composed of a 3 ½-digit FND display, five keys and of twelve LEDs located on the front membrane. The information displayed on screen depends on whether the sensors are present or not and on the related function enable. Using the buttons it is possible to navigate a cascade menu, which allows configuring individually the functions to be assigned to the 4 independent outputs.



Description of keys

-  Button **Up** to increase values. Used both for parameter modification and for moving inside the menus.
-  Button **Down** to decrease values. Used both for parameter modification and for moving inside the menus.
-  **Esc** Cancel and menu exit
-  **Set** Parameter programming and confirmation
-  **Ovr** Operating mode override

Description of Led

Ao1	Led associated to analogue output 1, it is on during data display.
Ao2	Led associated to analogue output 2, it is on during data display.
SR1	Led associated to control sensor 1, it is on during data display.
SC/SL	Led associated to limit/compensation sensor, it is on during data display.
SR2	Led associated to control sensor 2, it is on during data display.
DI1	Led associated to digital input 1, it is on when the input is active (closed contact).
DI2	Led associated to digital input 2, it is on when the input is active (closed contact).
Rel1	Led associated to relay output 1, it is on when the output is active.
Rel2	Led associated to relay output 2, it is on when the output is active.
	Led associated to anomaly signal.
Ovr	Led associated to override status of the <i>Operating Mode</i>
Mode	Led associated to <i>Operating Mode</i> . On Comfort Blinking Reduced Off Stop

FUNCTION DESCRIPTION

GENERAL

First of all it is necessary to define the **OPERATING MODE** for each one of the four Control Loops. The Operating Mode constitutes the functioning type to be assigned to a specific output. Heating control means that the output moves in an inversely proportional way with respect to the value measured by the **Control Sensor**, vice versa is the meaning of cooling control.

FOR THE 2 ANALOGUE OUTPUTS CAN BE SELECTED:

MODE A1: HEATING LOOP

If the output value must increase, while the Control Sensor value goes below the Operating Set. When the set point is achieved the output is zero. If the control Temperature goes below the **Heating Set Point** value (SPC) minus the **Heating Proportional Band** (BPC) the relevant analogue output goes to 100%, equivalent to 10 Vdc.

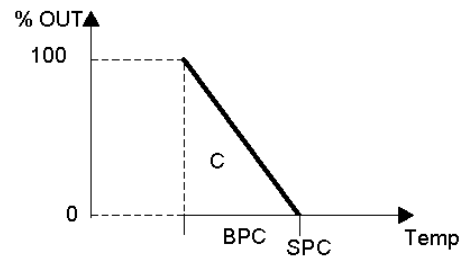

MODE A2: COOLING LOOP

If the output value must increase, while the Control Sensor value goes above the Operating Set. When the set point is achieved the output is zero. If the control Temperature goes above the **Cooling Set Point** value (SPF) plus the **Cooling Proportional Band** (BPF), the relevant analogue output goes to 100% equivalent to 10 Vdc.

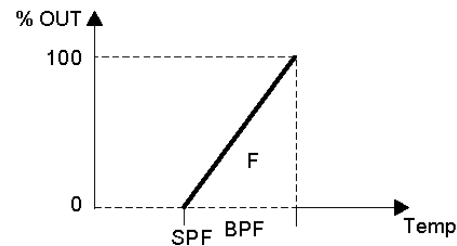

MODE A3: HEATING / COOLING LOOP FROM S/W CHANGEOVER

If the Heating or Cooling Loop is enabled through the contact input (D.i.2) in order to carry out a season changeover. When the D.i.2 contact is open, the Loop passes to "Heating" control type, under closed contact the Loop passes to "Cooling" control type. The two "Set" (SPC, SPF) and the two proportional bands (BPC, BPF) are independent.

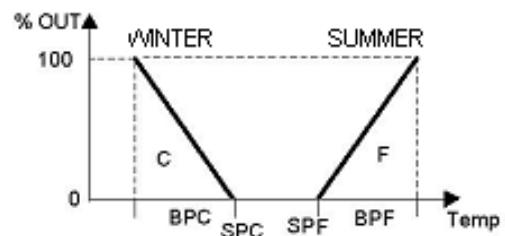

MODE A4: HEATING LOOP / COOLING IN SEQUENCE

If it is required to exploit the 0-5 6-10 V control characteristic of CONTROLLI actuators to realize a Heating Cooling sequence with a unique 0–10 Vdc analogue output. When the set point is achieved the output is 5,5 Vdc. If the control Temperature goes below the **Heating Set Point** value (SPC) minus **Heating Proportional Band** (BPC), the relevant analogue output goes to 0 Vdc. If the control Temperature goes above the value the **Cooling Set Point** value (SPF) plus **Cooling Proportional Band** (BPF) the relevant analogue output goes to 10 Vdc.

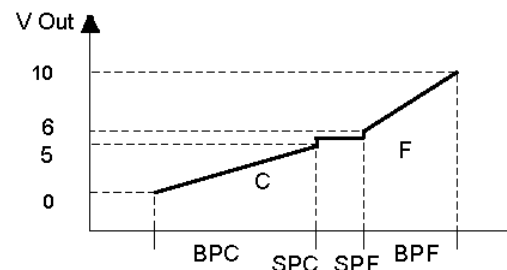

In this case, if a heating-Cooling sequence is required, the two actuators must be connected in parallel to the same output selecting the range 0 – 5 Vdc with reverse action for the actuator, which manages the heating channel, while for the actuator managing the Cooling channel, it is necessary to select the range 6 – 10 Vdc with direct action.

FOR THE 2 ON/OFF DIGITAL RELAY OUTPUTS CAN BE SELECTED:

MODE D1: ON/OFF HEATING HYSTERESIS

If the output value must turn to ON when the value of the Control Sensor goes below the Operating Set minus the Hysteresis band. When the set point is achieved, the relay output is in OFF status.

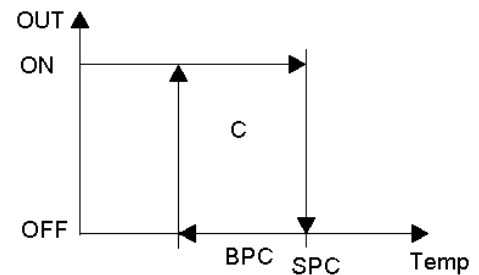

MODE D2: ON/OFF COOLING HYSTERESIS

If the output value must turn to ON when the value of the Control Sensor goes above the Operating Set plus the Hysteresis band. When the set point is achieved, the relay output is in OFF status.

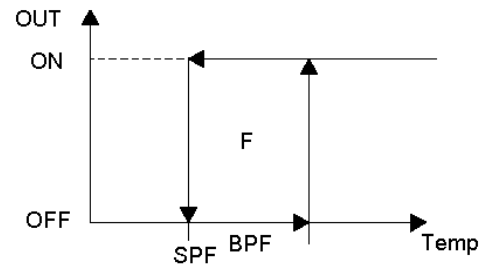

MODE D3: HEATING / COOLING HYSTERESIS FROM S/W CHANGEOVER

If it is required to enable the heating or cooling hysteresis through the contact input (D.i.2) to carry out a season changeover. When the D.i.2 contact is open, the Loop passes to “Heating” control type, under closed contact the Loop passes to “Cooling” control type. The two “Set” (SPC, SPF) and the two proportional bands (BPC, BPF) are independent.

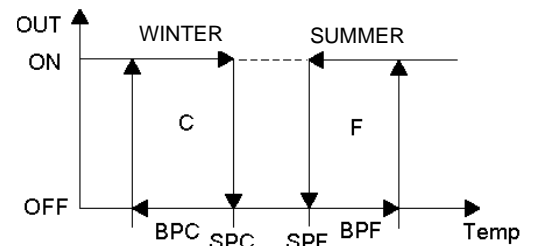

MODE D4: ON/OFF DELAY

If it is required to enable or disable a relay output with a specified delay at stop and/or start. The delay is considered with respect to an event, which can be:

- Operating Mode (NM and RF => ON, FA => OFF), if a stop and/or start delay of a device following the Operating Mode is required.
- The status of one of the two digital inputs (D.i.1 or D.i.2), if it is required a stop and/or start delay of a device following the status of one or both dry contact inputs.
- The status of the other Relay output, if it is required a stop and/or start delay of a device following the status of the other digital relay output.

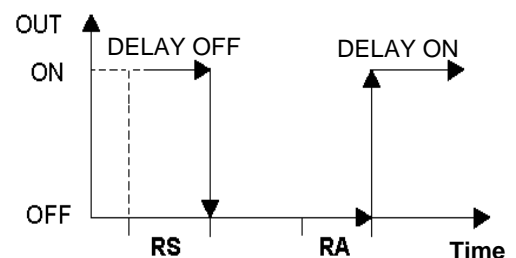

The ON Delay (**RA**) and the Off Delay (**RS**) can be set individually in seconds.

The events generating the changeover are according to an “OR” logic, which means that, if more than one event condition is enabled, it is sufficient that only one is true.

The maximum allowed delay is 30 minutes.

For all Set point and Band parameter settings, see page 15.

CONTROL TYPE

Once the **OPERATING MODE** is stated, it is necessary to set the **CONTROL TYPE**, i.e. the control criteria used by the OPERATING MODE. The control type can be:

- Proportional or Proportional + Integral (P or P+I)
- With fixed operation set point or compensated in function of Compensation Sensor.
- With or without minimum and/or maximum limit in function of Limit Sensor.

At this point, to improve the device understanding, it is necessary to recall some basic concepts about the used control type used.

PROPORTIONAL CONTROL (P)

Given a SET POINT (required value), the difference between this value and the VALUE detected by the Control Sensor is called ERROR.

A proportional control is obtained when the value of a controller output moves proportionally to the ERROR. The PROPORTIONAL BAND determines the quantity of the action (gain) in function of ERROR. When the ERROR is equal to the PROPORTIONAL BAND the output value is equal to 100 %.

Setting a too small PROPORTIONAL BAND can generate oscillation phenomena of the output. Setting an excessively wide PROPORTIONAL BAND can generate a change from the SET of the controlled temperature.

PROPORTIONAL CONTROL + INTEGRAL (P+I)

If to P action is added an I action, the result is a more accurate control, which takes into account the error variation in time. It is necessary to define an INTEGRATION TIME, which states the time, after which the Proportional action is restored. Generally, INTEGRAL action is necessary when the PROPORTIONAL BAND allows a variation, conferring to the INTEGRAL action the task to cancel the remaining error.

PROPORTIONAL CONTROL+INTEGRAL+DERIVATIVE

If the D (derivative) action is added to PI action the result is a more fast action according to the system dynamics. It is necessary to set a derivative gain to state a suitable action.

Note: The effects of the derivative action are emphasized if fast actuators are used! In case of slow actuators, the action D is not perceived.

The two 0-10 Vdc analogue outputs can be P, P+I or P+I+D, therefore, the parameters to be set for each output will be:

- SET POINT (with fixed-point control)
- PROPORTIONAL BAND
- INTEGRATION TIME (if I action is enabled)
- DERIVATIVE CONSTANT (if D action is enabled)

The 2 relay outputs can be only P, the parameters to be set will be:

- SET POINT (with fixed-point control)
- HYSTERESIS BAND

The Control Sensor used for Ao1 and Do1 Loops is the one connected to **SR1** terminal and for Ao2 and Do2 is the one connected to SR2 terminal, if not differently specified ("SR sharing" see paragraph related to Link Bus). If the control sensors are not connected correctly to **SR1** and/or **SR2** terminal or is not shared correctly with other devices the Anomaly led  lights up.

In the OPERATING MODE 4D, the relay output behaves as a timed sequencer and it controls in function of time events and not in function of temperature.

See page 20 to set the Operating Modes and control types.

SET-POINT COMPENSATION

The operation SET POINT can be fixed or determined by a compensation curve in function of the value read by the relevant sensor. The compensation curve is a broken line passing between two points defined by four values. In function of the value read by the Sensor, a SET-POINT value in a range between a minimum and a maximum will be defined. *Negative Compensation* occurs when the Operation Set-point increases while the value measured by the compensation sensor decreases. *Positive Compensation* occurs when the Operation Set-point increases while the value of the Compensation Sensor increases. It is possible to set both Negative and Positive Compensations both for heating and for cooling control Loop.

Each Operation Set-point value, both in heating and cooling control Loop, can be associated to its own compensation curve expressed by a value pair:

- SET-POINT 1 corresponding to TEMPERATURE 1
- SET-POINT 2 corresponding to TEMPERATURE 2

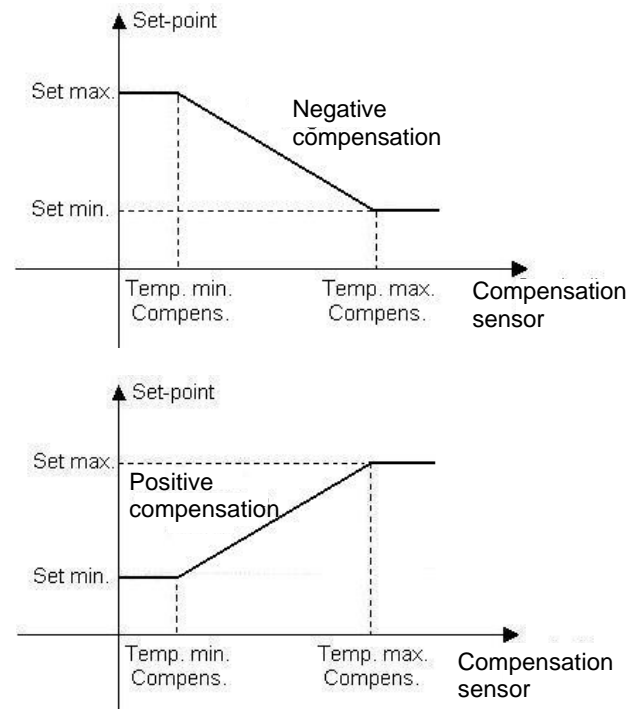

If a sensor is present on SC/SL terminal and the input is configured as Compensation sensor, it is possible to enable the Compensation sensor and to state the four values of the curve.

Such values become eight in case of Operating Mode A3, A4 and D3 because it is necessary to set a compensation both for the heating and for the cooling loops. In the latter case, if compensation should be disabled for only one of the two Loops, it is necessary to set the minimum Set-point equal to the maximum value achieving a fixed operation Set-point. It is not possible to enable compensation in Operating Mode D4.

The Compensation Sensor used is the one connected to **SC/SL** input, if not differently specified (“SC sharing” see paragraph related to Link Bus). To enable Compensation first connect or share the Compensation Sensor. If compensation is enabled on any Operating Mode and the Compensation Sensor is not connected correctly to **SC** terminal or is not shared correctly with other devices, the Anomaly led  lights up and the control Set-point becomes the value set for fixed point, i.e. without Compensation.

For all compensation parameters settings see page 15.

MINIMUM AND/OR MAXIMUM LIMITS

Limit Loops are P-type only and always operate with fixed Set point. If enabled, they work in parallel to the control Loop. For each Operating Mode (except Mode D4) the minimum and/or maximum limits are enabled individually. In presence of active Limits, the output values will be determined by the set parameters. For each control Loop 4 settings are possible:

- Disabled limits
- Minimum limit enabled
- Maximum limit enabled
- Minimum and a maximum limit enabled

The behaviour of a limit Loop output will be different if the Loop is in heating or cooling Mode. For A3, A4 and D3 operating Modes, it will be possible to enable the minimum and/or maximum limits both for heating and cooling Mode.

The term “Minimum limit” indicates a function intended to avoid that the temperature measured by the Limit Sensor **SL goes below** the specified values.

The term “Maximum limit” indicates a function intended to avoid that the temperature measured by the Limit Sensor SL **overcomes** the specified values.

THEREFORE:

In a **HEATING LOOP:**

If the **Minimum limit** function is enabled, it uses the output **maximum value** among the limit Loop and Control Loop. If the **Maximum limit** function is enabled, it uses the output **minimum value** among the limit Loop and Control Loop.

In a **COOLING LOOP:**

If the **Minimum limit** function is enabled, it uses the output **minimum value** among the limit Loop and Control Loop. If the **Maximum limit** function is enabled, it uses the output **maximum value** among the limit Loop and Control Loop.

If the Minimum limit is enabled, it is necessary to define:

- MINIMUM LIMIT SET POINT
- MINIMUM LIMIT PROPORTIONAL BAND

If the Maximum limit is enabled it is necessary to define:

- MAXIMUM LIMIT SET POINT
- MAXIMUM LIMIT PROPORTIONAL BAND

For Operating Modes A3, A4 and D3 it is necessary to set the Limit Set and Band values both for heating Loop and for cooling Loop. It is not possible to enable the limit function in Operating Mode D4. The Limit Loop Set-point operates at fixed point and is not modified even under *Reduced Operating Mode*. The Limit Loop is disabled under *Stop Operating Mode*. The Limit function can also be used to create a Control Loop, which performs a control of the SL sensor value independently from sensor SR (see following paragraph).

If a sensor is present on SC/SL terminal and the input is configured as Limit sensor, it is possible to enable the Limit function.

The **Limit Sensor** used is the one connected to **SC/SL** input, if not differently specified (“SL sharing” see paragraph related to Link Bus). Connect or share the **Limit Sensor** before enabling the minimum and/or maximum Limit. If the Limit is enabled on any Operating Mode and the **Limit Sensor** is not connected correctly to **SC/SL** terminal or is not shared correctly with other devices, the Anomaly Led  switches on.

For all limit parameters settings see page 15.

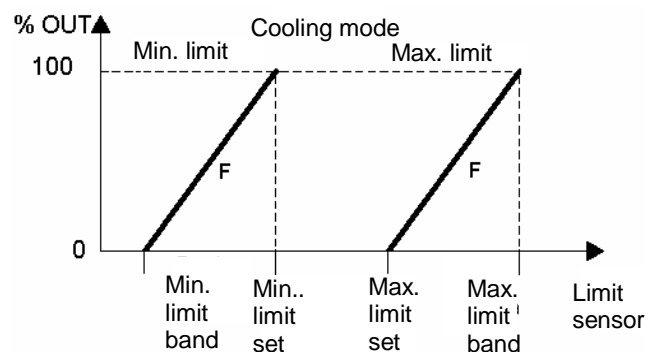
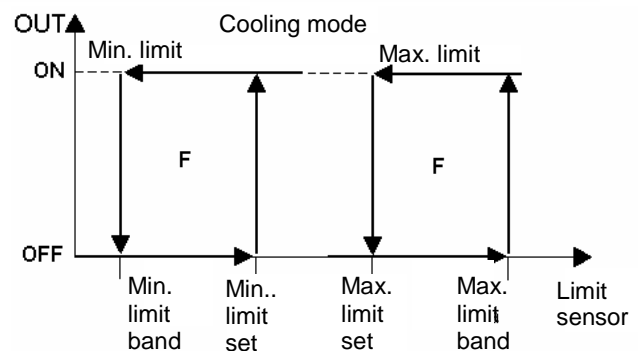
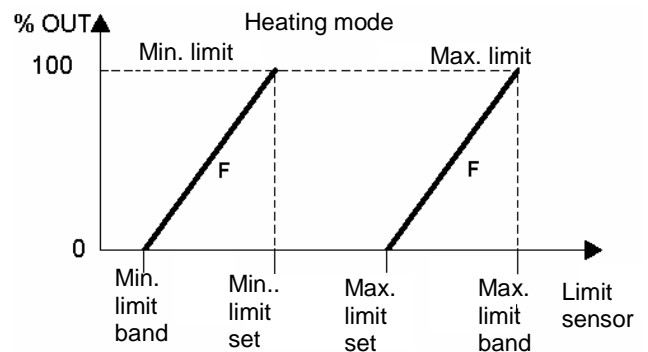
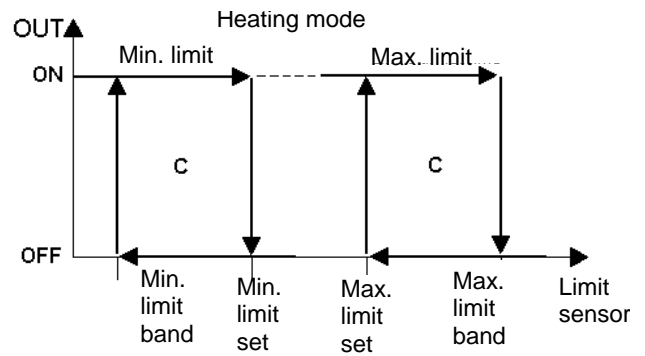

OPERATING MODE

The equipment is able to operate according to three different operating modes, which are:

- 0) **Comfort** – all loops are ON during control (including the Limit Loop).
- 1) **Reduced** – the Control Loops operate on a reduced Set point. The Limit Loops remain ON.
- 2) **Stop** – all loops are 0 (including the Limit Loop).

The Operating Mode acts on all Control Loops also in Mode D4 (sequence controller), in which Comfort and Reduced modes have the same meaning.

The passage from an Operating Mode to another can take place as follows:

- Using the suitable Manual override key **Ovr** . If it is pressed repeatedly, it is possible to access manually to one of the three modes. This function is enabled on each Control Loop, by setting ABO = On.
For further details see page 10.

- From *Time schedule*: it changes automatically into one of the three modes according to the time schedule.
This function is enabled on each Control Loop, by setting ABO = On.

The Ao1 and Do1 Loops are according to the PS1 weekly program and the P1 daily programme.

The Ao2 and Do2 Loops are according to the PS2 weekly program and the P2 daily programme.

- Through digital input D.i.1 and/or input D.i.2 (except modes A3 and D3); if enabled (AE1 = On and/or AE2 = On), it is possible to pass from Stop (open contact) to another mode, i.e.:

Changeover from digital inputs with dry contact operates on all Loops whose function is enabled (AE1 or AE2 with value On). Such operation has a priority with respect to other changeovers (from clock or Manual override button).

The Stop mode in Mode A4 produces a 5,5 Vdc output.

The enabled Operating Mode is signalled by a proper Led **Mode** on the front panel, as follows:

Led Mode Status	Operating Mode enabled
ON	Comfort
Blinking	Reduced
Off	Stop

Through the Link Bus, it will be possible to share the override mode although a local override on a single equipment has always priority with respect to the shared mode.

The Operating mode is determined by default by the Time schedule, if the clock is present, otherwise the default Operating Mode is Comfort. The manual override through key loses its action, if the equipment is switched off and then on again. For further details, see the three following paragraphs.

MANUAL OVERRIDE KEY FOR THE OPERATING MODE

It is possible to carry out a manual override of the Operating Mode by pushing the proper key **Ovr**  inside the *Operating Mode Programme Menu* accessed by pushing the **Set** key for 5 seconds.

The manual override cancels the mode determined by the clock and it is signalled by the Led **Ovr** on the front panel. The number of clicks on such key, states cyclically the setting, passing from Comfort, to Reduced and Stop modes, then returning to Automatic mode.

Note: “Ovr” key acts on both the control Loops.

CLOCK ENABLE WITH INDEPENDENT TIME SCHEDULE

If the equipment is RTC-provided, two weekly programmes are available with the daily programme; one combined to Ao1 and Do1 Loops the other combined to Ao2 and Do2 Loops.

If the W500 is connected via Link Bus to a device with clock, it is possible to define the Operating Mode according to the weekly schedule and the daily schedule of the Ao1 and Do1 Loop. The clock enable of each Control Loop is obtained by setting the parameter ABO = On. If the device with clock is connected to other equipments without clock through the Link Bus, the mode of the Ao1 and Do1 Loop can be shared and all the slave equipments will follow simultaneously the same time schedule.

Weekly schedule:

Two weekly programmes are available; one combined to Ao1 and Do1 Loops the other combined to Ao2 and Do2 Loops.

For each day of the week it is possible to define a fixed mode (On = Comfort, rid = Reduced, OFF = Stop) or to assign an whole daily schedule (expressed by PRO value).

Daily schedule:

Two daily programmes are available; one combined to P1 weekly programme the other combined to P2 weekly programme.

It is possible to carry out up to 4 time changeovers defining, for each one, hour, minute and mode.

The changeovers, which are not used, must be filled in with the same values of the last valid changeover.

For the setting of both weekly and daily time schedules, see page 20.

OUTSIDE DIGITAL ENABLE

Two digital inputs are available: they can be used independently by the 4 Control Loops to override the active operating mode. It is necessary to make a distinction between TMB model (with clock) and T model (without clock).

In both models, if the parameter Abo = OFF (enabling by clock disabled) the Loop is STOPPED; if the parameter Abo = ON, it follows the time schedules in TMB model and it is always in Comfort mode in T model.

At this point, if on a Control Loop the Outside enable has been started with AE1 parameter = ON and/or AE2 parameter = ON:

In TMB model

the D.I. 1 and/or D.I.2 contacts enable the Loop outside the timetable

In T model

nothing happens (the loop remains in COMFORT mode)

If Abo parameter = OFF and AE1 parameters = ON and/or AE2 parameters = ON, and if the D.I. 1 and/or D.I. 2 contacts are open, the Loop is STOPPED. If one or both of them are closed, the Loop is in COMFORT mode.

If the Loop is configured to operate in A3 or D3 mode (Heating/Cooling by S/W changeover) the digital input 2 is only used for this purpose.

The enabling from contact (Loop starting override) has priority on other changeovers (from clock or manual override with **Ovr** key).

Operating Mode	Contact D.i.1 AE1 = On		Contact D.i.2 (*) AE2 = On	
	Open	Closed	Open	Closed
COMFORT	STOP	COMFORT	STOP	COMFORT
RIDOTTO	STOP	REDUCED	STOP	REDUCED
STOP	STOP	COMFORT	STOP	COMFORT

(*) This function is not active in A3 and D3 modes.

FACTORY DATA LOAD

Through this function it is possible, if required, to reset all the factory settings of parameters. This function is useful for example when the user has set different values and requires restoring the initial conditions in a short time.

STORING DATA IN PERMANENT MEMORY

Once the parameters for a plant are set, it is possible to store such settings in order to restore them when required.

LOADING DATA FROM PERMANENT MEMORY

This function allows restoring all the configurations and the parameters, which were previously saved by MEMORY DATA STORAGE function.

REMOTE SET

When a control with Fixed-point set is required, the Compensation Sensor is not used. In this case, it is possible to connect a suitable potentiometer (instead of the **Compensation Sensor** local input) to carry out a remote setting of the Operation Set-point.

PARAMETER SETTING

Enable Compensation and define the four points of the line:

Keep into the account that TEMPERATURE 1 corresponds to the value read at a potentiometer end and TEMPERATURE 2 to the value read at the other end.

- SET 1 corresponding to TEMP 1
- SET 2 corresponding to TEMP 2

The value displayed by the Compensation Sensor is purely indicative and does not correspond to the actual temperature in °C.

OUTSIDE SENSOR FROM SUPERVISION FOR COMPENSATION

If the function is ON (USE = On), it is possible to carry out compensation through a value sent from the Communication Bus with ModBus protocol (supervision). In practice it is a virtual sensor, which can be used instead of a real sensor connected to **SC** terminal. If, for example, there is only one outside sensor in the whole plant, this function allows using its value on all controllers connected to the supervision system. Similarly it would be possible, from supervision, to set a single Operation Set-point for the different equipments connected.

LINK BUS COMMUNICATION

The Link Bus serial communication port allows to 2, 3 or 4 equipments to interoperate for data exchange. The Link Bus connection allows sharing the three sensors and Operating Mode and supervising the devices, which do not have the RS485 serial communication port.

The equipments connected via Link Bus must have a univocal address (IDL) that can be set by the menus from 1 to 4. The equipment with IDL = 1 (Master) communicates its Operating Mode to the other controllers connected to the Link Bus. If the Master is RTC-provided (RTC is not necessary for the others), the 4 controllers can operate according to the same time schedule.

Note: The Slave controllers receive the time schedule by the Master.

The equipments without the RS485 (W500T2) serial communication port can be supervised if connected via Link Bus to at least one equipment with RS485 (W500T2MB), setting it as Master.

Each IDL address corresponds to a Link Bus “channel” on which the controller communicates the values of its own temperature sensors connected to the terminals. Each device communicates its values on the Link Bus channel determined by the assigned IDL address number. If it is required a sensor connected to the terminals of another controller, it is necessary to operate on parameters menu of Sensor Selection (SEL) and to select the channel for reading. For example, a controller with IDL address = 2, which uses the Compensation Sensor connected to SC terminals of the equipment having IDL address = 3, the value SSC in the sensor selection parameter menu (SEL) must be = 3. If the sensor to be used is connected to the controller terminals, the setting will be SSC = 2. For each one of three sensors it is necessary to specify its location. If the sensor is local, it is necessary to state the proper IDL address.

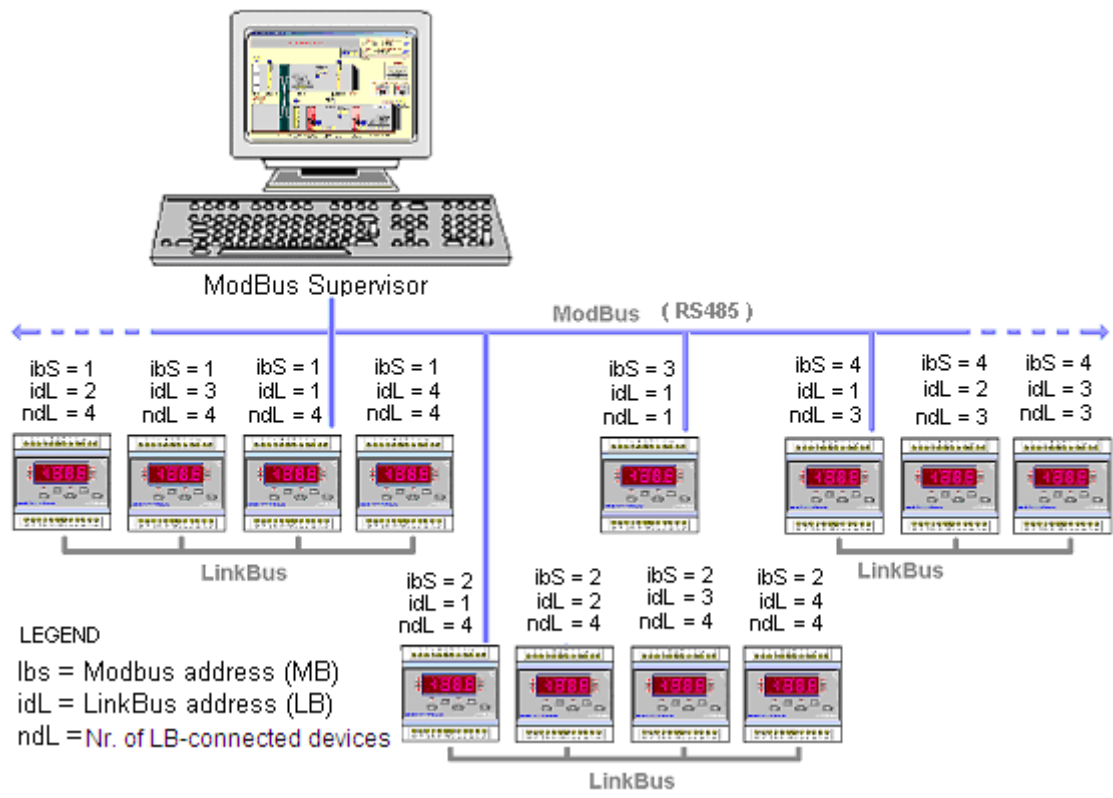

In order to communicate the values through the Link Bus port, it is also necessary to set the number of devices interconnected by the parameter NDL (4 max.). The equipments connected to the Link Bus, which must not transmit data, can be set with NDL = 1. Such configuration is allowed (to speed data exchange on the Link Bus), but it is not recommended in case of data monitoring via ModBus. The equipments connected to the Link Bus which do not communicate data, can receive data from other equipments. It is essential that:

- the other equipments have the same NDL value as the number of the controllers, communicating the values
- the equipments, which do not communicate data, have a higher IDL address.

The equipments, which are RTC-provided, always use the their Operating Mode changeover ignoring the Link Bus signal.

The max advisable distance between the two equipments at the Link Bus ends is 10 m. This distance should allow any connection inside the electrical board. In case of power devices (Contactors, Inverters, UPS, reactors, etc.) it is **strongly recommended to use shielded cables** with the screen connected to earth at one point only and to keep at a suitable distance (30 cm. at least) the power cables and the signal wires, otherwise use metal pipes.

It is advisable to use a 24AWG or 26AWG twisted-pair cable and do not carry out star connections.

For setting the Link Bus address and to select one of the sensors shared, see page 15.

MODBUS COMMUNICATION

Through the ModBus protocol it is possible to supervise up to 255 groups of 4 equipments, for a total of 1020 devices. The ModBus connection is carried out on the equipment defined with **IDL = 1** (Master) through the RS485 serial port. The values managed by supervision and those managed by the controller menu are the same. For the address values of ModBus data, refer to the proper Database documents supplied on request.

The wiring path between the two most distant devices connected to RS485 serial must not exceed 1000 m.: we recommend to use a 24AWG or 26AWG twisted-pair cable and not to carry out star connections.

The first and the last device must be terminated by a 120-Ohm ¼-Watt resistance.

If devices from different manufacturers are present on the same communication Bus, it is necessary to respect the limits imposed and to be careful not to use the same ModBus addresses of other devices. We recommend using a shielded cable for RS485 Bus if on the plant or inside the switchboard are present power devices, always keeping the suitable distances and precautions regarding signal wiring and power cables.

For ModBus address set up and outside compensation from supervision, see page 20.

ERROR SIGNALLING

The controller is able to signal two anomaly conditions, one depending from communication and the other from Sensors.

If a Communication ERROR is present, the Anomaly Led 🚫 blinks. It is possible to have a communication fault when, for example, two equipments connected via Link Bus use the same IDL address or in case of high noise on communication, which provokes faulty data transmission. Inside switchboards, in presence of power devices (contactors, Inverters, UPS, reactors, etc.), **we recommend to use shielded cables** (both for sensors and Bus) to reduce anomaly probability.

If a sensor anomaly occurs, the Anomaly Led 🚫 lights up. If both anomaly conditions occur, the Led blinks. Once the Communication anomaly is cancelled, the Led remains on indicating the Sensor ERROR.

For a correct operation the anomaly Led must be switched off.

The conditions, which most frequently produce anomalies, are:

- Sensor is no more present with enabled function
- Sensor outside the controller (shared with Link Bus) is not present
- More devices have the same IDL address

FRONT PANEL AND DATA ACCESS MENU

Using Front Panel, it is possible to access the Parameters managed by the device. The data access Menu is subdivided into three different levels:



Level 0 – Main data display

Level 1 – Access to parameter configuration menu

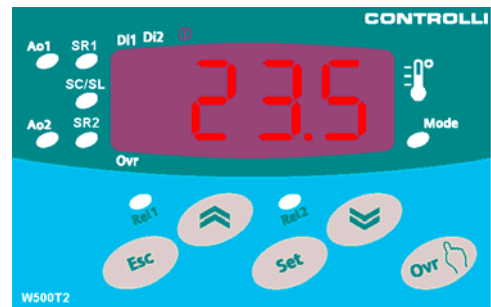
Level 2 – Access to the Operating modes programming menu



The **Level 0** is the one displayed by default. If no keys are pushed for some seconds this level is automatically re-entered from the higher levels.

At this Menu level it is possible to visualize on the FND display the temperature values of the connected sensors (also via Link Bus) and the analogue outputs Ao1 and Ao2 values expressed as a percentage. Data display is achieved by pushing the buttons **Up**  or **Down** ; while Led signalling the displayed analogue input or output lights up. If an input is not present, it is not displayed. The digital input led **D.i.1** and **D.i.2** are on with closed contact, the **Rel1** and **Rel2** relay output led are on if they are energized. Such led are always visible at any menu level. The **Mode**, **Ovr** and anomaly  LEDs have already been described in the respective chapters.

To access **Level 1**, push the Set key. At this level it is possible to change the control Parameters of the two analogue outputs [**PA1**] and [**PA2**], of the two Relay Digital outputs [**Pd1**] and [**Pd2**] and, for W500T2MB controllers only, also the clock [**rtc**]. It is always necessary to set the clock at the first start-up or if the equipment has been powered off for over 30 hours. In order to set date and time, scroll the menu at the level 1 until the corresponding label [**rtc**] is reached. The label [**d00**] (days, d00 = Monday) appears by pushing the **Set** key. Push the buttons **Up** or **Down** to set. If the key are not pushed for some seconds or by pressing **Set**, the label [**h00**] (hours) and [**'00**] (minutes) appears: push the buttons **Up** and **Down** to set respectively hour and minutes. To confirm and save, push **Set**. If the keypad is not pushed or by pressing the **Esc** key once, the start value appears.

[**PA1**] label corresponds to the Parameters of Analogue output 1 at **Ao1** terminal

[**PA2**] label corresponds to the Parameters of Analogue output 2 at **Ao2** terminal

[**Pd1**] label corresponds to the Parameters of Digital output 1 of **Rel1** relay

[**Pd2**] label corresponds to the Parameters of Digital output 2 of **Rel2** relay

To modify a parameter, it is necessary to push **Set** after selecting the corresponding Label; the parameter value blinks and can be changed by pushing the keys **Up** to increase or **Down** to decrease. Push **Set** or **Esc** to exit. For the complete control parameter navigation see the *Parameter Configuration Menu* scheme on page 166.

By pushing the **Set** key for at least 5 seconds, **Level 2** appears. At this menu level, it is possible to set:

- the Operating-Set decrease to Reduced mode
- the operating modes of the two analogue outputs [**PA1**], [**PA2**] and of the two relay outputs [**Pd1**] and [**Pd2**]
- the address parameters for sensor selection and the SC/SL sensor function [**SEL**], for the communication [**BUS**], for data load [LdE], save [**SdE**], restore [**dEF**] and, for W500T2MB devices only, also the time schedules for the automatic changeover of the weekly and daily Operating Mode [**PRO**].

For data navigation see *Programme menu for operating mode and time schedules* on page 20 Note: the time schedules are present only on W500T2MB.

PARAMETER CONFIGURATION MENU

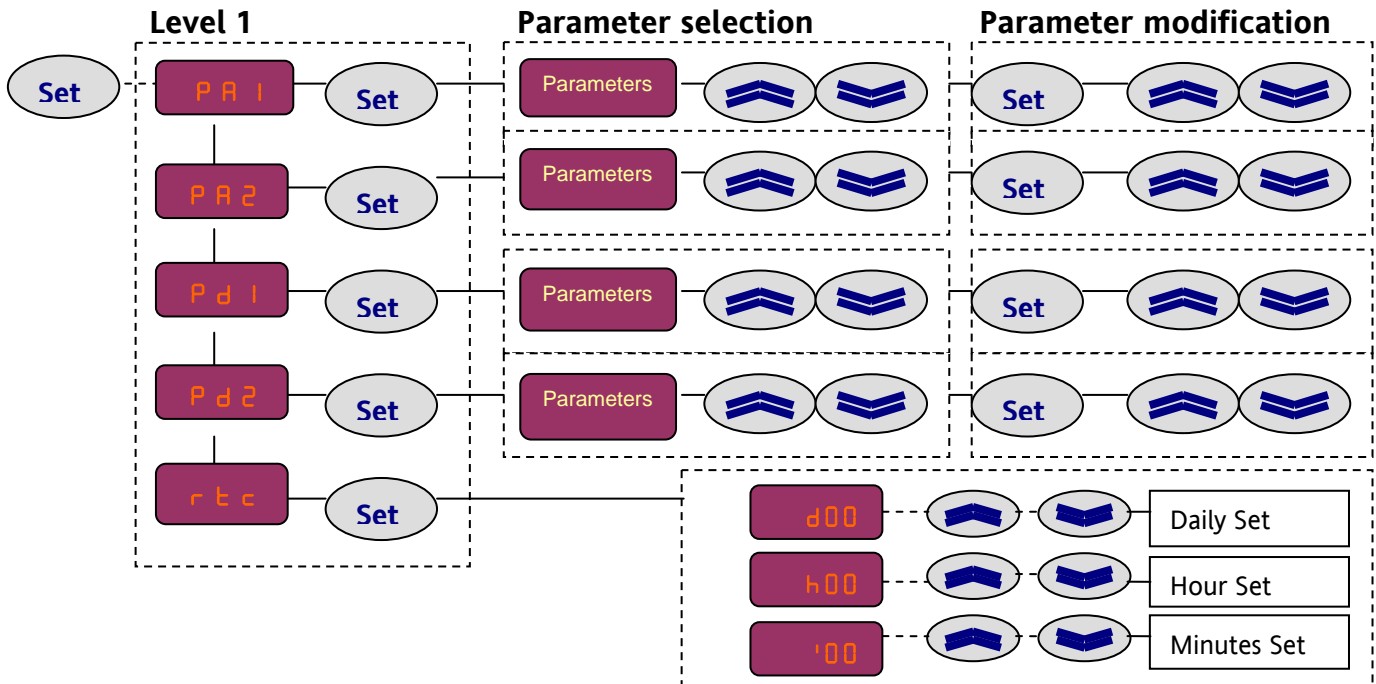

Parameters - Mode A1

Push the **Set** Key to change of the relevant parameter. The parameter value blinks showing the edit status: push the **Up** and **Down** keys to change values. Once the desired values are modified, push the **Set** or **Esc** keys to exit.

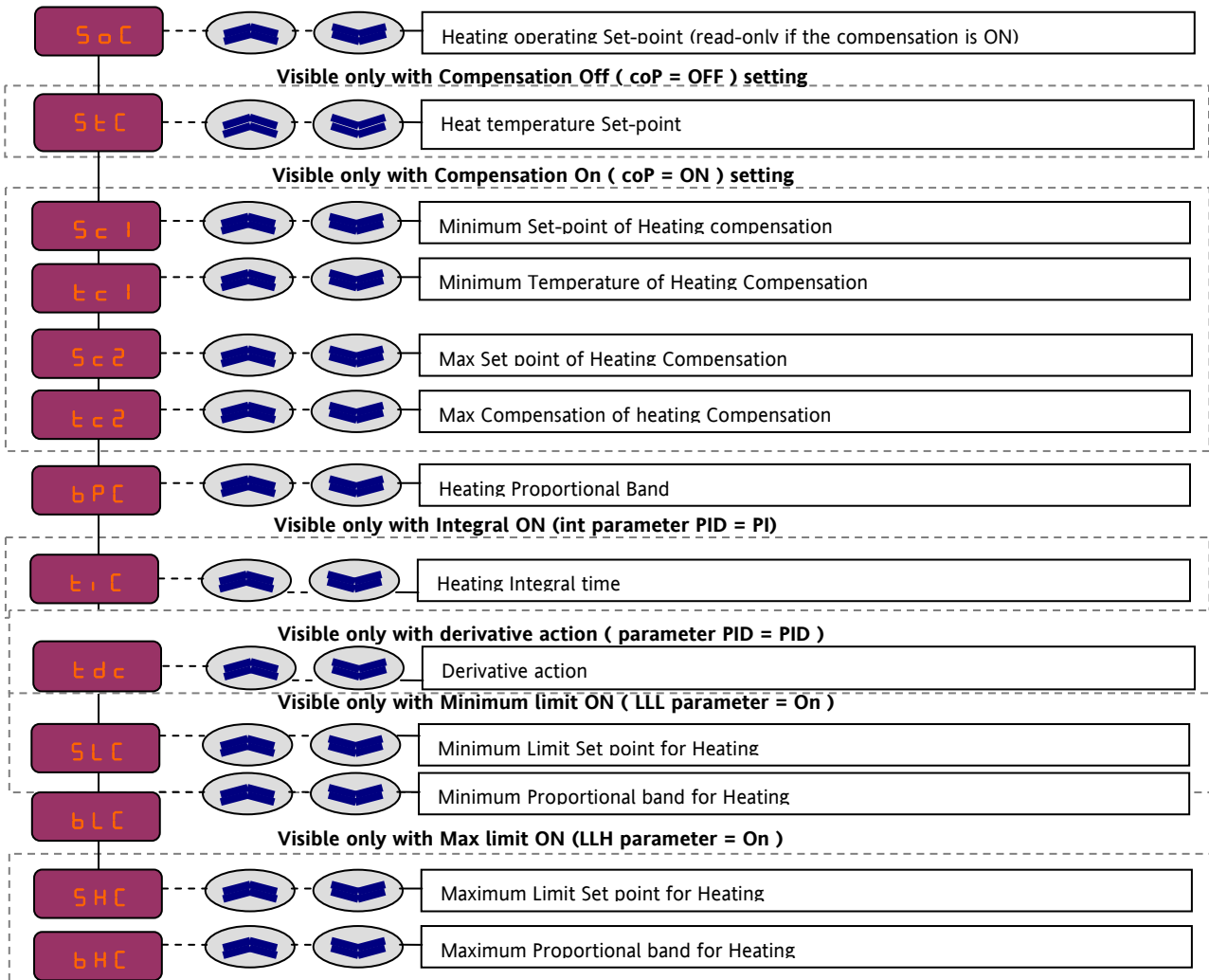

Parameters - Mode A2

Push **Set** key to select the parameter to be modified. The parameter value blinks showing the edit status: push the **Up** and **Down** keys to change values. Once the desired values are modified, push the **Set** or **Esc** keys to exit.

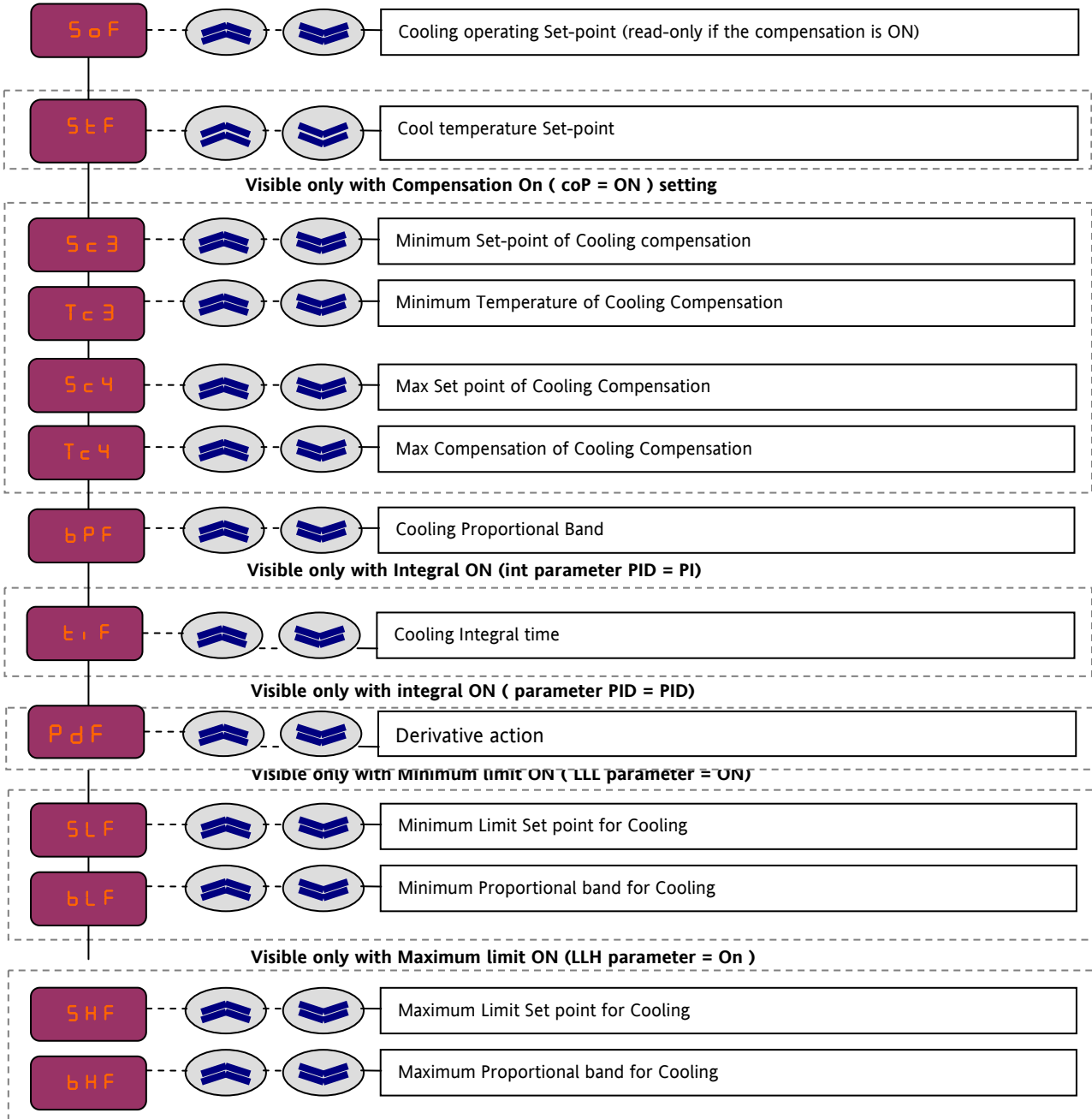

Parameters - Mode A3 / Mode A4

The parameter menu of the Analogue Operating Modes A3/A4 is the sum of A1/A2 Modes parameter menus. This Menu contains all parameters, since this modes are intended manage both heating and cooling control loops.

Push **Set** key to select the parameter to be modified. The parameter value blinks showing the edit status: push the **Up** and **Down** keys to change values. Once the desired values are modified, push the **Set** or **Esc** keys to exit.

The Compensation/Integral/Limit parameters are visible if the relevant functions in the Operating Mode Programme menu (2° Level) are enabled. Push **Set** key for 10 seconds to enter the menu.

Parameters - Mode D1

Push **Set** key to select the parameter to be modified. The parameter value blinks showing the edit status: push the **Up** and **Down** keys to change values. Once the desired values are modified, push the **Set** or **Esc** keys to exit.

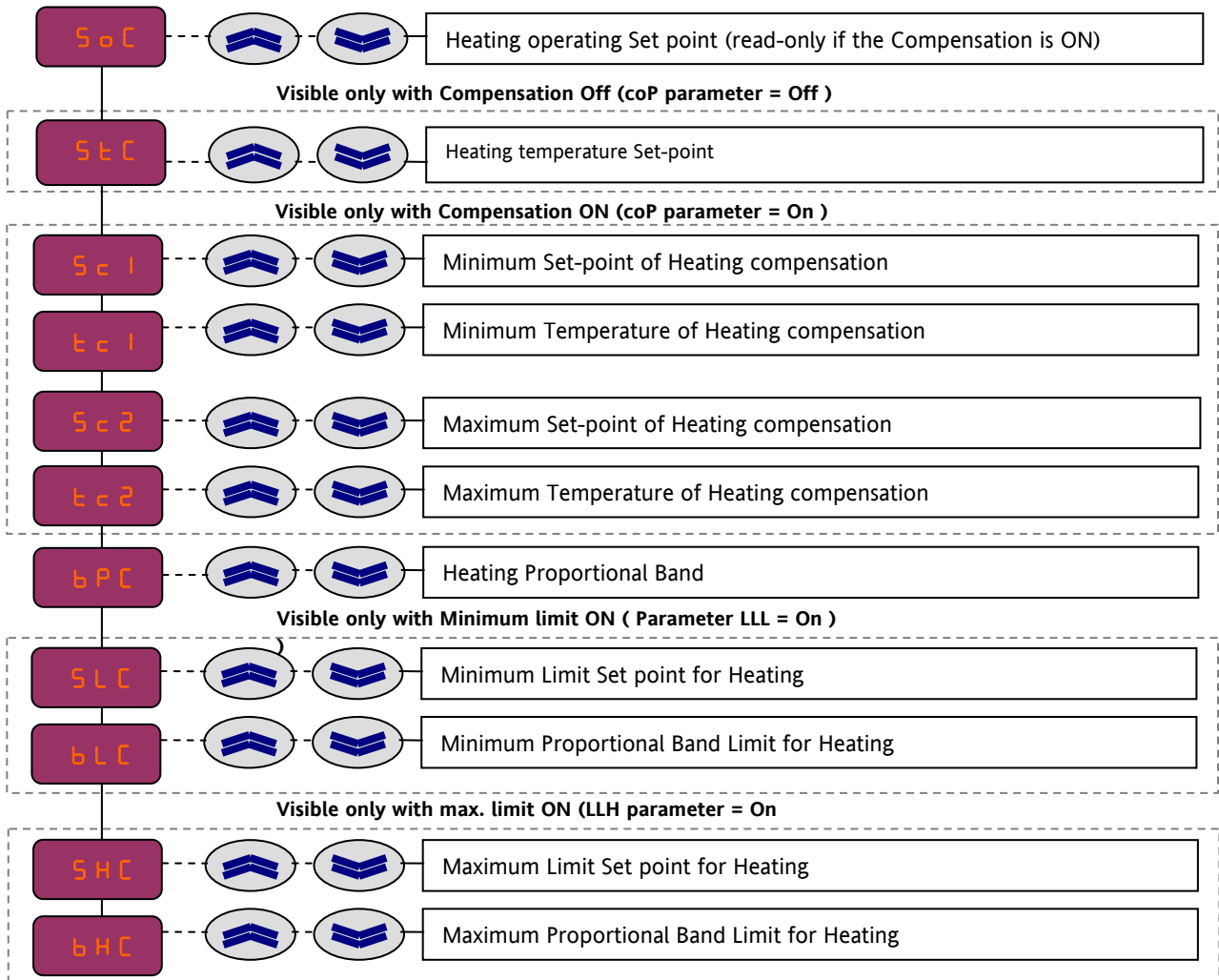

Parameters - Mode D2

Push **Set** key to select the parameter to be modified. The parameter value blinks showing the edit status: push the **Up** and **Down** keys to change values. Once the desired values are modified, push the **Set** or **Esc** keys to exit.

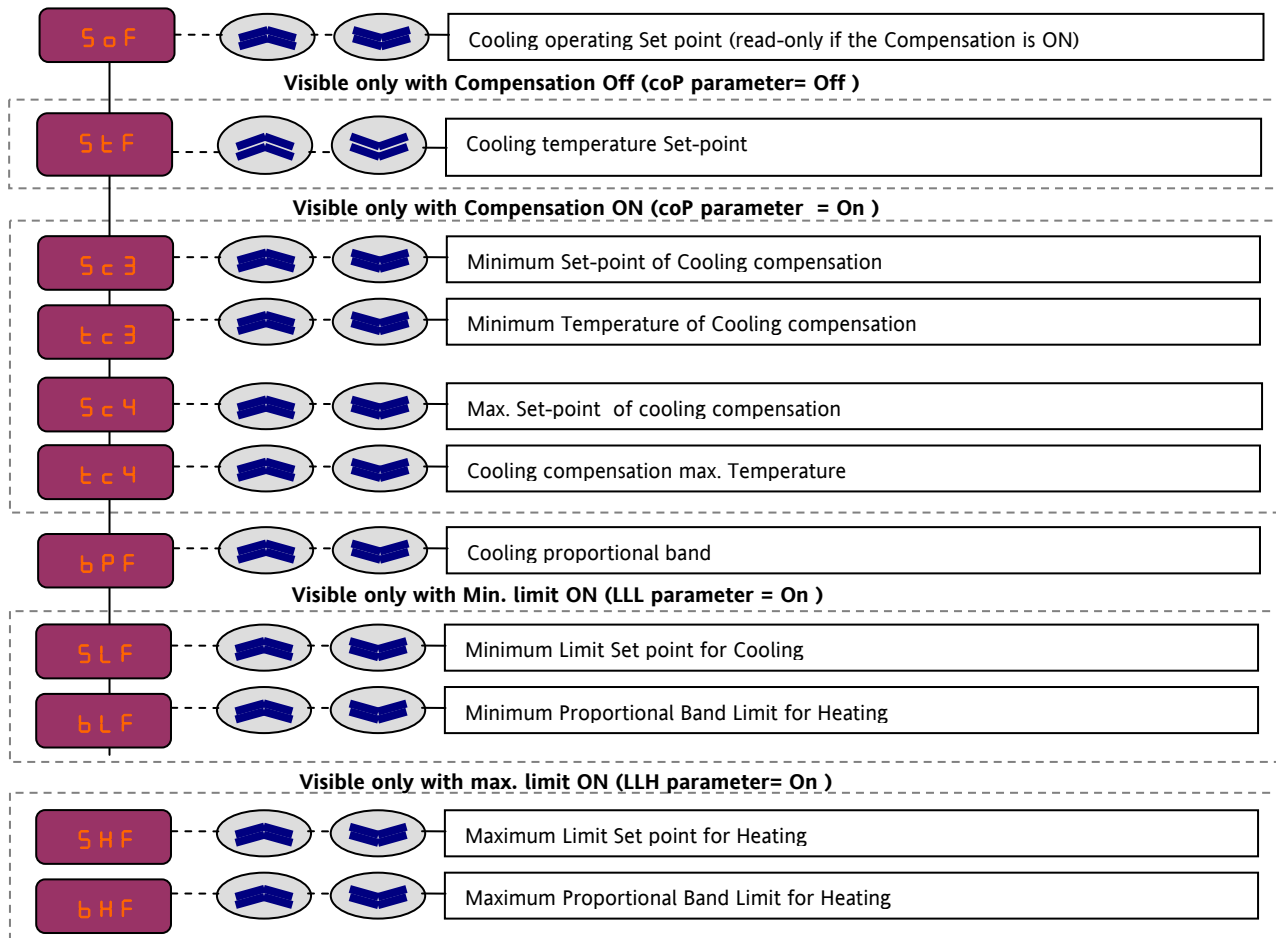

Parameters - Mode D3

The Parameter menu of On/OFF Hysteresis Digital operating Mode D3 is the sum of D1/D2 Modes parameter menus. This Menu contains all parameters, since this mode is intended to manage both heating and cooling control loops.

Push **Set** key to select the parameter to be modified. The parameter value blinks showing the edit status: push the **Up** and **Down** keys to change values. Once the desired values are modified, push the **Set** or **Esc** keys to exit.

The Compensation and Limit parameters are visible if the relevant functions in the Operating Mode Programme menu (2° Level) are enabled. Push **Set** key for 10 seconds to enter such menu

Parameters - Mode D4

Push **Set** key to select the parameter to be modified. The parameter value blinks showing the edit status: push the **Up** and **Down** keys to change values. Once the desired values are modified, push the **Set** or **Esc** keys to exit.

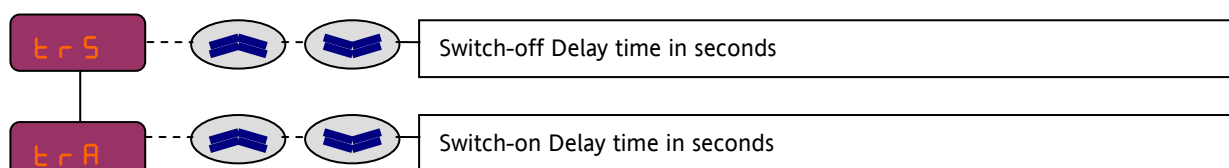

Output override setting

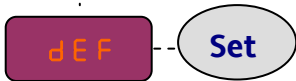
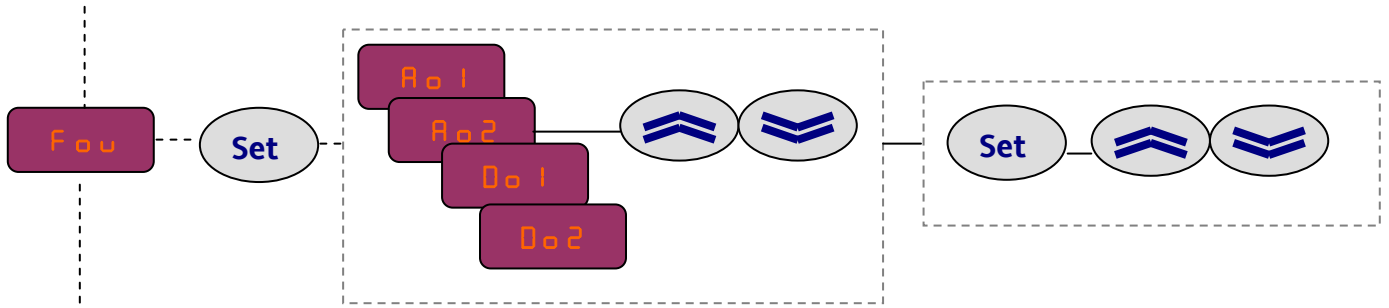

Push **Set** for 10 seconds until the device is reset (the display blinks)

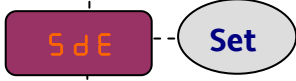

Push **Set** for 10 seconds until the label **YES** appears (the display blinks)

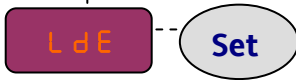

Push **Set** for 10 seconds until the equipment is reset (the display blinks)

Settings - 0-10Volt Analogue Outputs (PA1 and PA2)

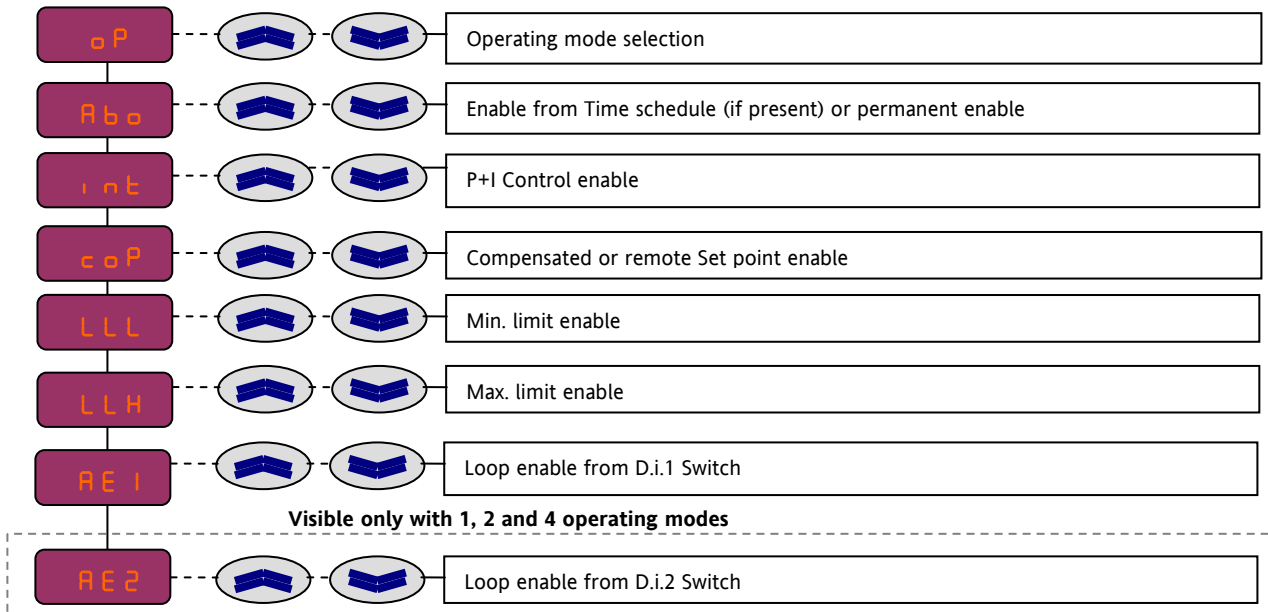

Settings - Relay Digital Outputs (Pd1 and Pd2) – Operating Modes 1, 2 and 3

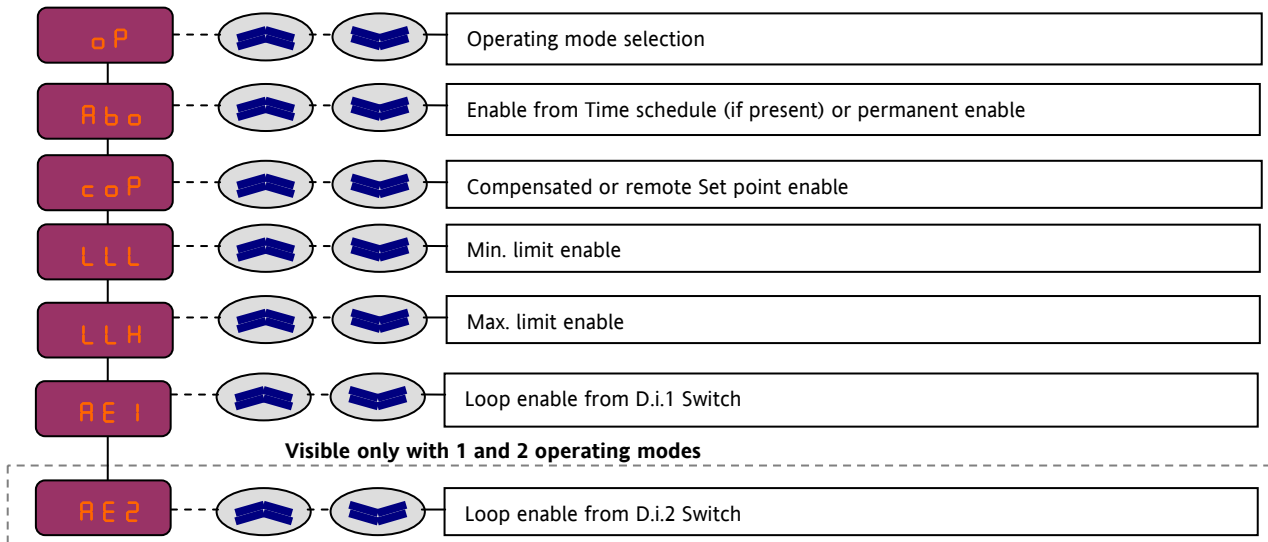

Setting - Relay digital Outputs (Pd1 and Pd2) – Operating Mode 4

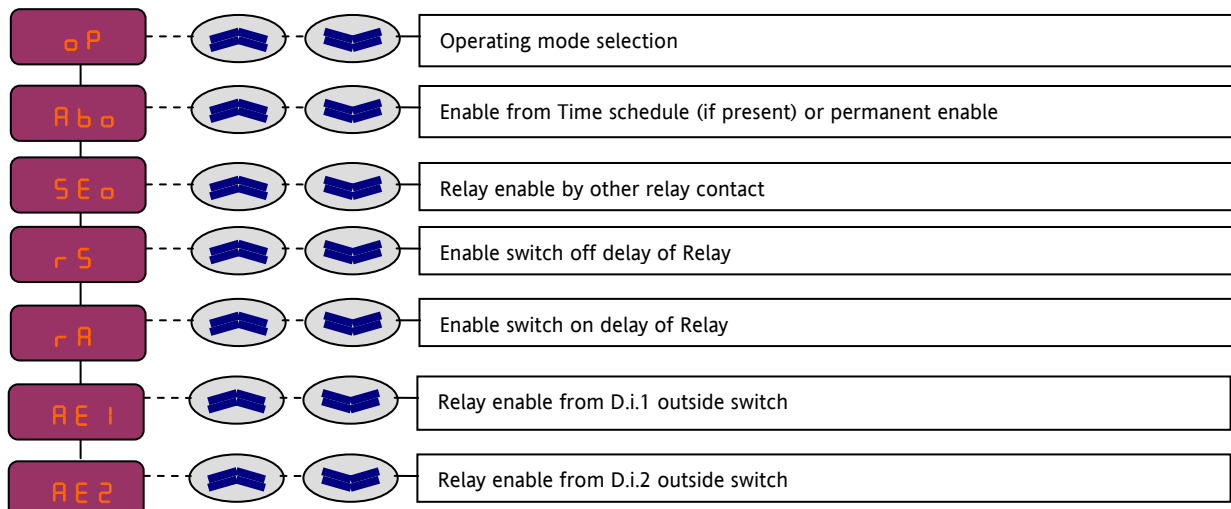

MENU DIAGRAM

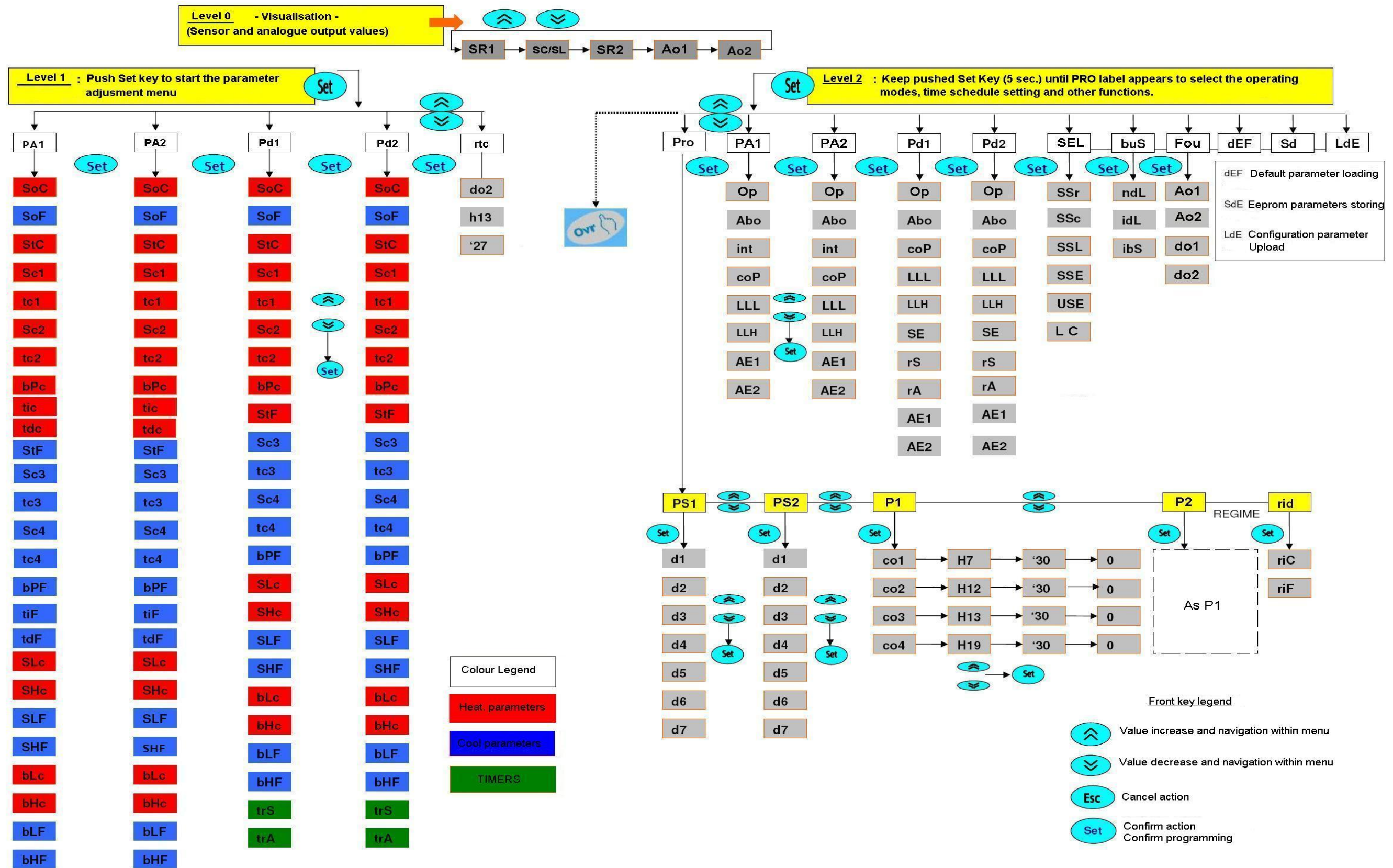

CONTROL PARAMETER TABLES (LEVEL 1)

Parameter table: Level 1 (Loop adjustment Parameters)

Analogue Controller PA1 & PA2	Default	Range	Description	Availability
SoC	--		Heat operating Set	Always (Visualisation only, cannot be set)
SoF	--		Cool operating Set	Always (Visualisation only, cannot be set)
StC	21.0	-50 to 150	Heat Loop Set	With SR, without Compens., 1, 3 and 4 operating mode
Sc1	20.0	-50 to 150	Heating compensation min. Set	With SR and SC, Comp. enabled, 1, 3 and 4 operating mode
tc1	5.0	-50 to 150	Heating compensation min. temperature	With SR and SC, Comp. enabled, 1, 3 and 4 operating mode
Sc2	35.0	-50 to 150	Heating compensation max. Set	With SR and SC, Comp. enabled, 1, 3 and 4 operating mode
tc2	10.0	-50 to 150	Heating compensation max. temperature	With SR and SC, Comp. enabled, 1, 3 and 4 operating mode
tiC	480	30 to 1200	Heating integral time (sec)	With integral action enabled
tdc	0	0 to 1000	Derivative constant	With derivative action enabled
bPc	4.0	0 to 25	Heating Loop Proportional Band	With SR, 1, 3 and 4 operating mode
SLc	18.0	-50 to 150	Heating min. limit Loop Set	With LLL enabled, 1, 3 and 4 operating mode
SHc	24.0	-50 to 150	Heating max. limit Loop Set	With LLH enabled, 1, 3 and 4 operating mode
SLF	18.0	-50 to 150	Cooling min. limit Loop Set	With LLL enabled, 2, 3 and 4 operating mode
SHF	24.0	-50 to 150	Cooling max. limit Loop Set	With LLH enabled, 2, 3 and 4 operating mode
bLc	4.0	0 to 25	Heating min. limit Proportional Band	With LLL enabled, 1, 3 and 4 operating mode
bHc	4.0	0 to 25	Heating max. limit Proportional Band	With LLH enabled, 1, 3 and 4 operating mode
bLF	4.0	0 to 25	Cooling min. limit Proportional Band	With LLL enabled, 2, 3 and 4 operating mode
bHF	4.0	0 to 25	Cooling max. limit Proportional Band	With LLH enabled, 2, 3 and 4 operating mode
StF	23.0	-50 to 150	Cooling Loop Set	With SR, without Compens., 2, 3 and 4 operating mode
Sc3	10.0	-50 to 150	Cooling compensation min. Set	With SR and SC, Comp. enabled, 2, 3 and 4 operating mode
tc3	10.0	-50 to 150	Cooling compensation min. Temperature	With SR and SC, Comp. enabled, 2, 3 and 4 operating mode
Sc4	30.0	-50 to 150	Cooling compensation max. Set	With SR and SC, Comp. enabled, 2, 3 and 4 operating mode
tc4	15.0	-50 a 150	Cooling compensation max. Temperature	With SR and SC, Comp. enabled, 2, 3 and 4 operating mode
tiF	480	30 a 1200	Cooling integral time (sec)	With integral action enabled
tdf	0	0 to 1000	Derivative constant	With derivative action enabled
bPF	4.0	0 to 25	Cooling Loop Proportional Band	With SR, 2, 3 and 4 operating mode

Reg. On/Off Pd1 & Pd2	Default	Range	Description	Availability
SoC	--		Heating operating Set	Always (Visualisation only, cannot be set)
SoF	--		Cooling operating Set	Always (Visualisation only, cannot be set)
StC	21.0	-50 to 150	Heating ON/OFF Set	With SR, without Compens., 1 and 3 operating mode
Sc1	20.0	-50 to 150	Heating compensation min. Set	With SR and SC, Comp. enabled, 1 and 3 operating mode
tc1	5.0	-50 to 150	Heating compensation min. Temperature	With SR and SC, Comp. enabled, 1 and 3 operating mode
Sc2	35.0	-50 to 150	Heating compensation max. Set	With SR and SC, Comp. enabled, 1 and 3 operating mode
tc2	10.0	-50 to 150	Heating compensation max. Temperature	With SR and SC, Comp. enabled, 1 and 3 operating mode
bPc	4.0	0 to 25	Heating ON/OFF Hysteresis	With SR, 1 and 3 operating mode
SLc	18.0	-50 to 150	Heating min. ON/OFF limit Set	With LLL enabled, 1 and 3 operating mode
SHc	24.0	-50 to 150	Heating max. ON/OFF limit Set	With LLH enabled, 1 and 3 operating mode
SLF	18.0	-50 to 150	Cooling min. ON/OFF limit Set	With LLL enabled, 2 and 3 operating mode
SHF	24.0	-50 to 150	Cooling max. ON/OFF limit Set	With LLH enabled, 2 and 3 operating mode
bLc	4.0	0 to 25	Heating min. ON/OFF limit Hysteresis	With LLL enabled, 1 and 3 operating mode
bHc	4.0	0 to 25	Heating max. ON/OFF limit Hysteresis	With LLH enabled, 1 and 3 operating mode
bLF	4.0	0 to 25	Cooling min. ON/OFF limit Hysteresis	With LLL enabled, 1 and 3 operating mode
bHF	4.0	0 to 25	Cooling max. ON/OFF limit Hysteresis	With LLH enabled, 1 and 3 operating mode
StF	24.0	-50 to 150	Cooling ON/OFF Set	With SR, without Compens., 2 and 3 operating mode
Sc3	8.0	-50 to 150	Cooling compensation min. Set	With SR and SC, Comp. enabled, 2 and 3 operating mode
tc3	0.0	-50 to 150	Cooling compensation min. temperature	With SR and SC, Comp. enabled, 2 and 3 operating mode
Sc4	15.0	-50 to 150	Cooling compensation max. Set	With SR and SC, Comp. enabled, 2 and 3 operating mode
tc4	40.0	-50 to 150	Cooling compensation max. temperature	With SR and SC, Comp. enabled, 2 and 3 operating mode
bPF	4.0	0 to 25	Cooling ON/OFF Hysteresis	With SR, 2 and 3 operating mode
trS	0	0 to 1999	Switch off delay time (sec)	Operating mode 4
trA	0	0 to 1999	Switch on delay time (sec)	Operating mode 4

TABLES OF OPERATING MODES AND TIME SCHEDULES (LEVEL 2)

Parameter table: Level 2 (Time schedules, Operating modes, Special functions)

Time schedules (Pro)

Weekly schedule (PS1)

	Default	Range	Description	Availability
d1 (MON)	3	0 to 3	Fixed mode or daily sched.(On,rid,OFF,Prg)	If clock is present (W500T2MB model)
d2 (TUE)	3	0 to 3	Fixed mode or daily sched.(On,rid,OFF,Prg)	If clock is present (W500T2MB model)
d3 (WED)	3	0 to 3	Fixed mode or daily sched.(On,rid,OFF,Prg)	If clock is present (W500T2MB model)
d4 (THU)	3	0 to 3	Fixed mode or daily sched.(On,rid,OFF,Prg)	If clock is present (W500T2MB model)
d5 (FRI)	3	0 to 3	Fixed mode or daily sched.(On,rid,OFF,Prg)	If clock is present (W500T2MB model)
d6 (SAT)	1	0 to 3	Fixed mode or daily sched.(On,rid,OFF,Prg)	If clock is present (W500T2MB model)
d7 (SUN)	2	0 to 3	Fixed mode or daily sched.(On,rid,OFF,Prg)	If clock is present (W500T2MB model)

Weekly schedule (PS2)

	Default	Range	Description	Availability
d1 (MON)	3	0 to 3	Fixed mode or daily sched.(On,rid,OFF,Prg)	If clock is present (W500T2MB model)
d2 (TUE)	3	0 to 3	Fixed mode or daily sched.(On,rid,OFF,Prg)	If clock is present (W500T2MB model)
d3 (WED)	3	0 to 3	Fixed mode or daily sched.(On,rid,OFF,Prg)	If clock is present (W500T2MB model)
d4 (THU)	3	0 to 3	Fixed mode or daily sched.(On,rid,OFF,Prg)	If clock is present (W500T2MB model)
d5 (FRI)	3	0 to 3	Fixed mode or daily sched.(On,rid,OFF,Prg)	If clock is present (W500T2MB model)
d6 (SAT)	1	0 to 3	Fixed mode or daily sched.(On,rid,OFF,Prg)	If clock is present (W500T2MB model)
d7 (SUN)	2	0 to 3	Fixed mode or daily sched.(On,rid,OFF,Prg)	If clock is present (W500T2MB model)

Daily schedule (P1)

	Default	Range	Description	Availability
co 1: h	7	0 to 23	Change-over time 1	If clock is present (W500T2MB model)
: '	30	0 to 59	Change-over minutes 1	If clock is present (W500T2MB model)
: r	0	0 to 2	Change-over mode 1 (NM, RF, FA)	If clock is present (W500T2MB model)
co 2: h	12	0 to 23	Change-over time 2 (0-23)	If clock is present (W500T2MB model)
: '	30	0 to 59	Change-over minutes 2 (0-59)	If clock is present (W500T2MB model)
: r	1	0 to 2	Change-over mode 2 (NM, RF, FA)	If clock is present (W500T2MB model)
co 3: h	13	0 to 23	Change-over time 3 (0-23)	If clock is present (W500T2MB model)
: '	30	0 to 59	Change-over minutes 3 (0-59)	If clock is present (W500T2MB model)

: r	0	0 to 2	Change-over mode 3 (NM, RF, FA)	If clock is present (W500T2MB model)
co 4: h	19	0 to 23	Change-over time 4 (0-23)	If clock is present (W500T2MB model)
: '	0	0 to 59	Change-over minutes 4 (0-59)	If clock is present (W500T2MB model)
: r	2	0 to 2	Change-over mode 4 (NM, RF, FA)	If clock is present (W500T2MB model)

Daily schedule (P2)

	Default	Range	Description	Availability
co 1: h	7	0 to 23	Change-over time 1	If clock is present (W500T2MB model)
: '	30	0 to 59	Change-over minutes 1	If clock is present (W500T2MB model)
: r	0	0 to 2	Change-over mode 1 (NM, RF, FA)	If clock is present (W500T2MB model)
co 2: h	12	0 to 23	Change-over time 2 (0-23)	If clock is present (W500T2MB model)
: '	30	0 to 59	Change-over minutes 2 (0-59)	If clock is present (W500T2MB model)
: r	1	0 to 2	Change-over mode 2 (NM, RF, FA)	If clock is present (W500T2MB model)
co 3: h	13	0 to 23	Change-over time 3 (0-23)	If clock is present (W500T2MB model)
: '	30	0 to 59	Change-over minutes 3 (0-59)	If clock is present (W500T2MB model)
: r	0	0 to 2	Change-over mode 3 (NM, RF, FA)	If clock is present (W500T2MB model)
co 4: h	19	0 to 23	Change-over time 4 (0-23)	If clock is present (W500T2MB model)
: '	0	0 to 59	Change-over minutes 4 (0-59)	If clock is present (W500T2MB model)
: r	2	0 to 2	Change-over mode 4 (NM, RF, FA)	If clock is present (W500T2MB model)

Reduced Set (rid)

	Default	Range	Description	Availability
RiC	3	0 to 20	Heating Set decrease	Always
RiF	5	0 to 20	Cooling Set decrease	Always

Operating modes

Analogue contr. PA1 & PA2

	Default	Range	Description	Availability
Op	1	1 to 4	Operating mode (1, 2, 3, 4)	Always Note: for details about the Operating modes see also the data sheet
Abo	OFF		Automatic/Manual enable (Clock)	Always
PID	P	P, PI, PID	P, PI, PID action enable	Always
coP	OFF		Compensated set enable	With SC sensor
LLL	OFF		Min. limit loop (Low) enable	With SL sensor
LLH	OFF		Max. limit loop (High) enable	With SL sensor
AE1	OFF		Loop stop on DI1 (External enable 1)	Always
AE2	OFF		Loop stop on DI2 (External enable 2)	1, 2 and 4 operating mode. 3 Mode: S/W (off) Changeover

On/Off contr. Pd1 & Pd2

	Default	Range	Description	Availability
Op	1	1 to 4	Operating mode (1, 2, 3, 4)	Always
Abo	OFF		Automatic/Manual enable (Clock)	Always
coP	OFF		Compensated Set enable	With SC, 1, 2 and 3 operating mode
LLL	OFF		Min. (Low) ON/OFF limit enable	With SL, 1, 2 and 3 operating mode
LLH	OFF		Max. (High) ON/OFF limit enable	With SL, 1, 2 and 3 operating mode
AE1	OFF		Loop stop on DI1 (External enable 1)	Always
AE2	OFF		Loop stop on DI1 (External enable 2)	1, 2 and 4 operating mode. In Mode3: S(on)/W (off) Changeover
SEo	OFF		Other ON/OFF control enable	Operating mode 4
RS	OFF		Switch off delay enable	Operating mode 4
RA	OFF		Switch on delay enable	Operating mode 4

Special Functions

Sensor selection (SEL)

	Default	Range	Description	Availability
SSr	1	1 to 4	Control sensor selection	Always
SSc	1	1 to 4	Compensation sensor selection	Always
SSL	1	1 to 4	Limit sensor selection	Always
SSE	1	1 to 4	Selection for external sensor to device	Always
USE	OFF		Compensation sensor enable by ModBus	Always
LC	CO	LI CO	Sensor 2 function selection (Limit/compens.)	Always

Communication (buS)	Default	Range	Description	Availability
ndL	1	1 to 4	Number of devices on LinkBus (1 - 4)	Always
idL	1	1 to 4	LinkBus position (1 - ndL)	Always
ibS	1	1 to 255	ModBus Supervisor bus address	Always

OVERRIDE OUTPUTS

(Fou)	Default	Range	Description	Availability
Ao1	Aut.	Aut, On, Off	Override output Ao1	Always
Ao2	Aut.	Aut, On, Off	Override output Ao2	Always
do1	Aut.	Aut, On, Off	Override output do1	Always
do2	Aut.	Aut, On, Off	Override output do2	Always

SYSTEM APPLICATIONS

EXAMPLE 1:

A COMPENSATED CLIMATIC ZONE AND DOMESTIC WATER BOILER

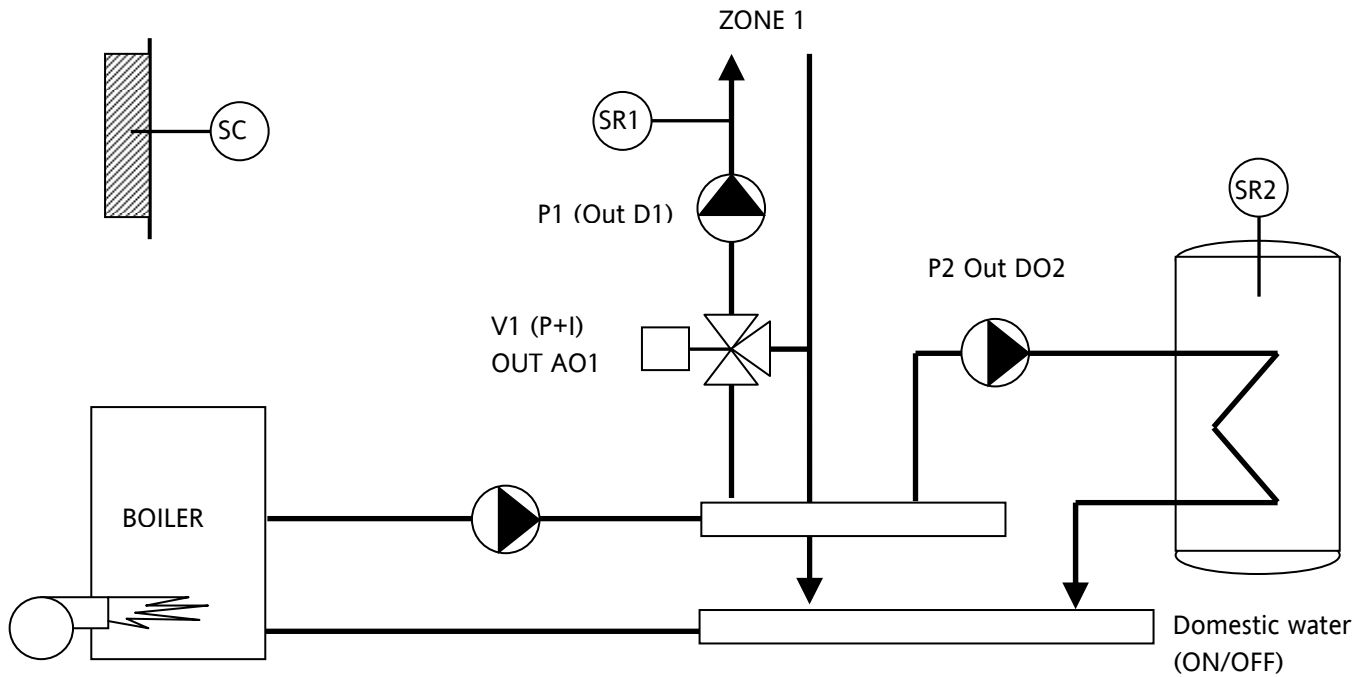

CLIMATIC ZONE

- 1 Weekly programme
- P1 Daily programme
- P+1 Control
- Compensated Set

DOMESTIC WATER (ON / OFF)

- 2 Weekly programme
- P 2 Daily programme
- P Control
- Fixed Set Point

**EXAMPLE 2:
A COMPENSATED CLIMATIC ZONE AND PROPORTIONAL DOMESTIC
WATER WITH DERIVATIVE ACTION**

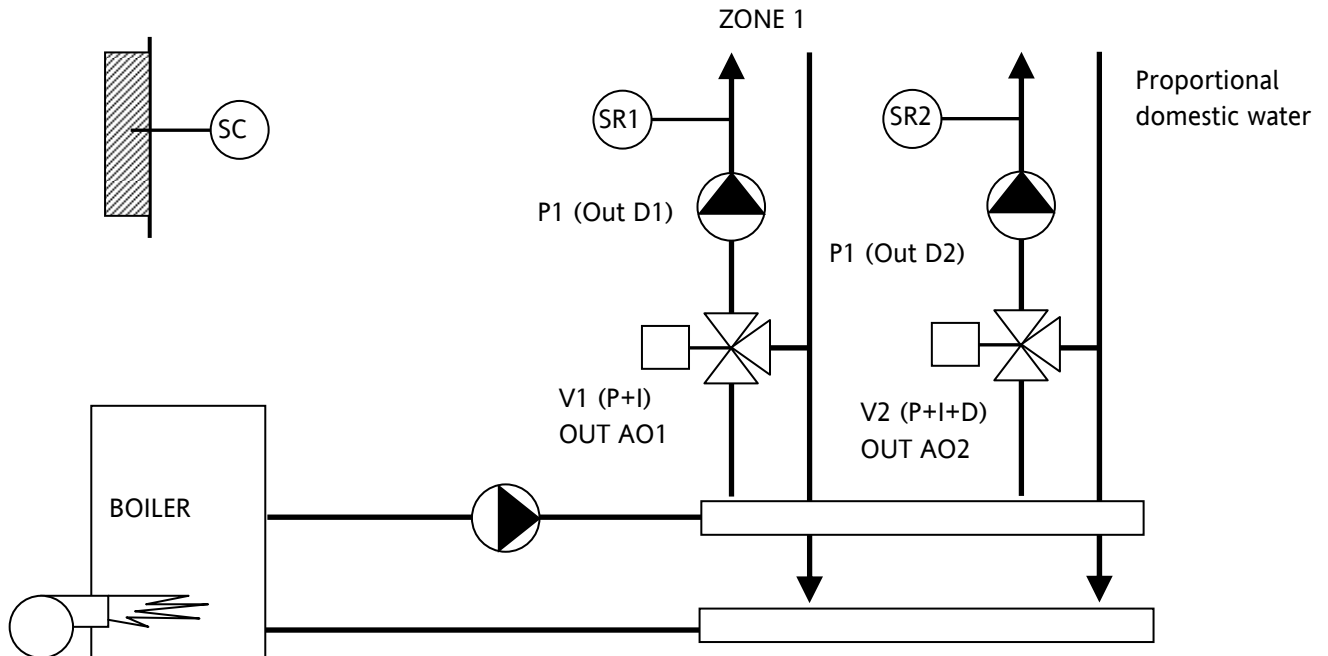

CLIMATIC ZONE

- 1 Weekly programme
- P1 Daily programme
- P+I control
- Compensated Set
-

DOMESTIC WATER (PROPORTIONAL)

- 2 Weekly programme
- P 2 Daily programme
- P+I+D Control
- Fixed Set Point