



Warnung

Lebensgefahr durch elektrische Spannung!
 Lesen Sie die Bedienungsanleitung, vor Beginn der Installationsarbeiten.
 Alle Installationsarbeiten sind in spannungsfreiem Zustand durchzuführen.

Warning

Electrical voltage! Danger to life!
 Read operating manual before starting installation work.
 All installation work must be performed under the absence of voltage.

Avertissement

Danger de mort par tension électrique!
 Lisez le manuel d'utilisation avant de commencer les travaux d'installation.
 Tous les travaux d'installation doivent être exécutés en l'absence de tension.

Waarschuwing

Levensgevaar door elektrische spanning
 Lees de instructies voordat u begint met de installatie.
 Alle installatiewerkzaamheden dienen uitgevoerd te worden in spanningsvrije toestand.

Avvertenza

Pericolo di morte dovuto alla presenza di tensione elettrica
 Leggere attentamente le istruzioni prima di iniziare il lavoro di installazione.
 Tutte le operazioni di installazione devono essere eseguite in assenza di tensione.

Peligro

Peligro de muerte por tensión eléctrica.
 Lea las instrucciones de servicio antes de empezar los trabajos de instalación.
 Todos los trabajos se tienen que realizar sin tensión.

DEU

ENG

FRA

NDL

ITA

ESP

► Lieferumfang / Scope of supply / Etendue de fourniture / Leveringsomvang / Volume di fornitura / Contenido del envío

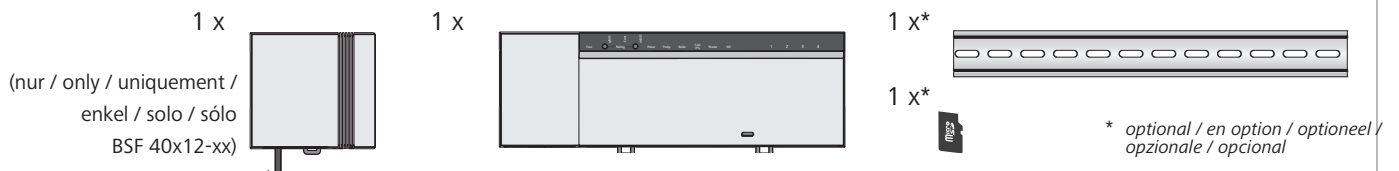

► Installation / Installatie / Installazione / Instalación

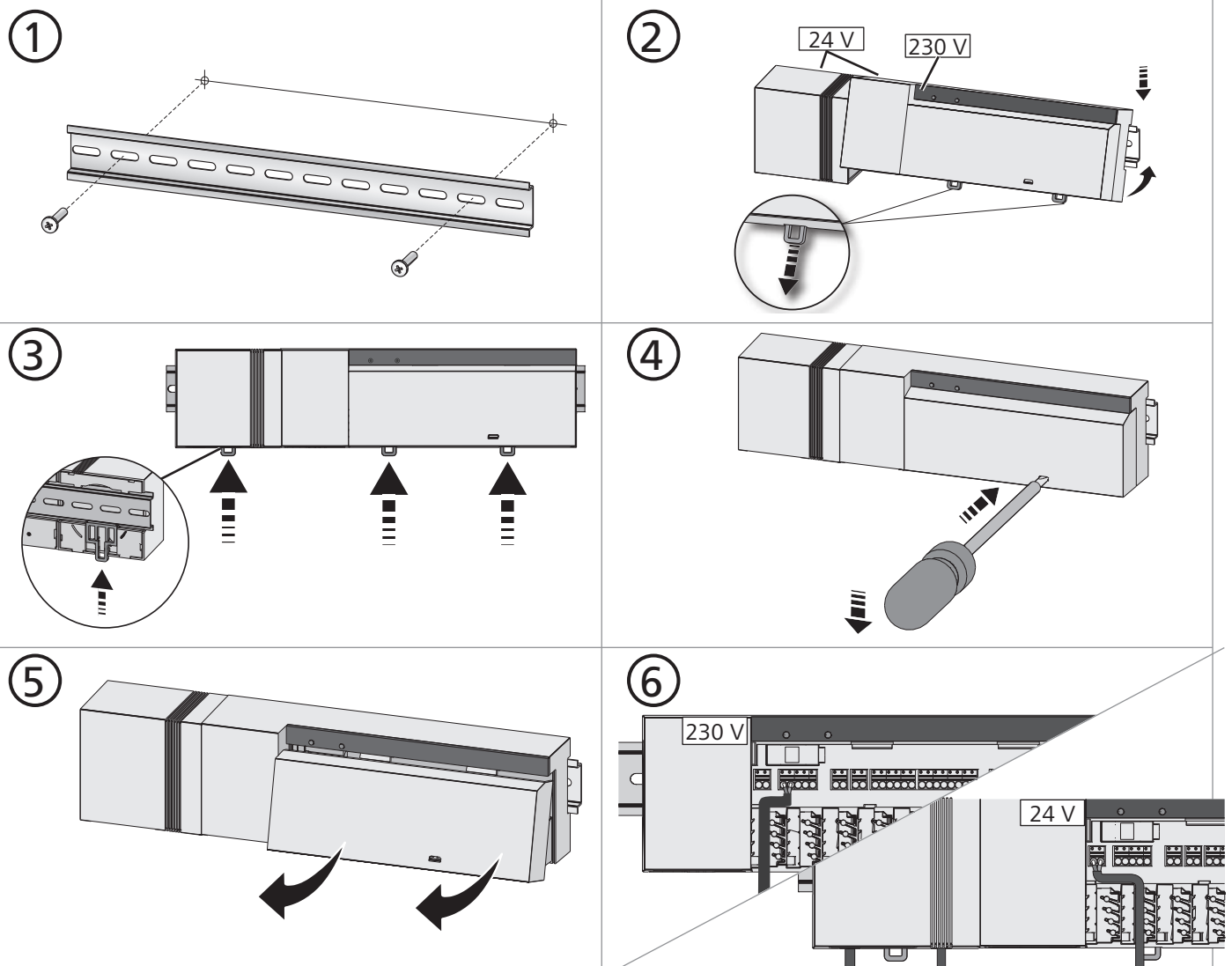

► 230 V: Elektrischer Anschluss / Electric connection / Branchement électrique / Elektrische aansluiting / Collegamento elettrico / Conexión eléctrica

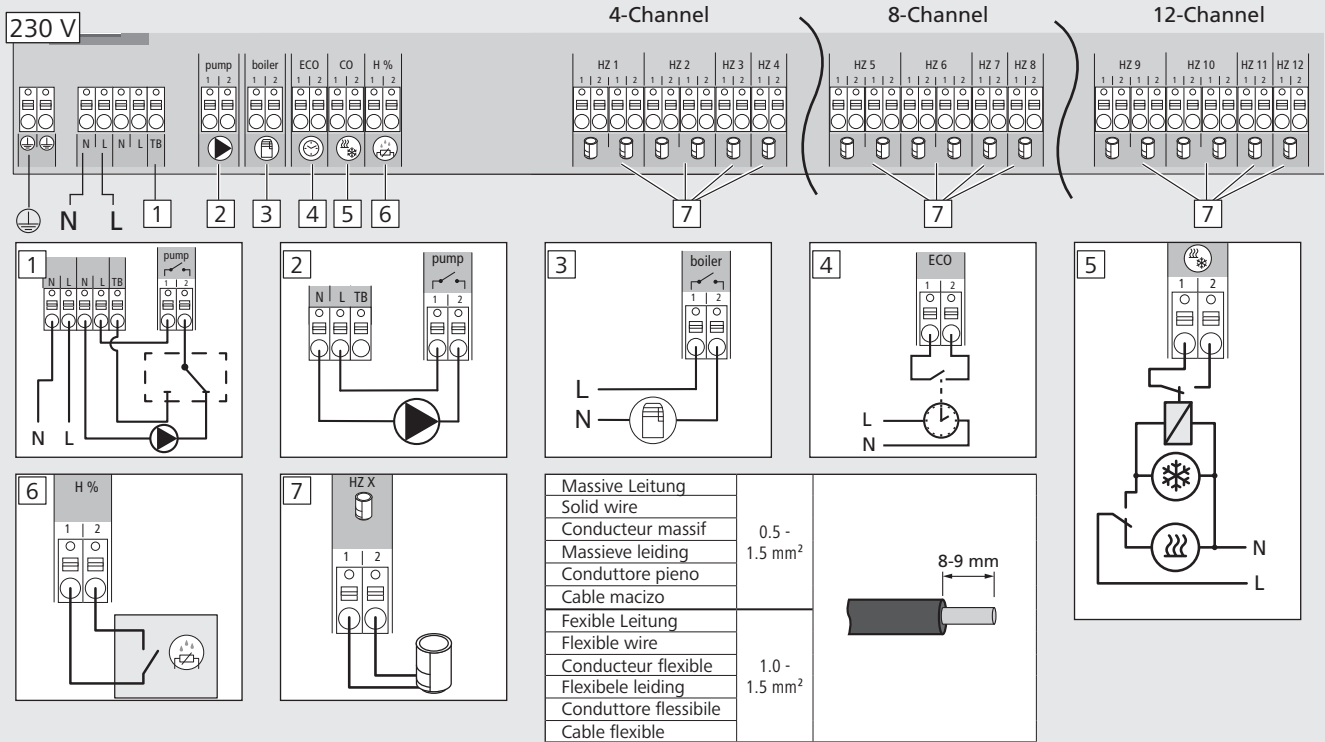

DEU
ENG
FRA
NDL
ITA
ESP

► 24 V: Elektrischer Anschluss / Electric connection / Branchement électrique / Elektrische aansluiting / Collegamento elettrico / Conexión eléctrica

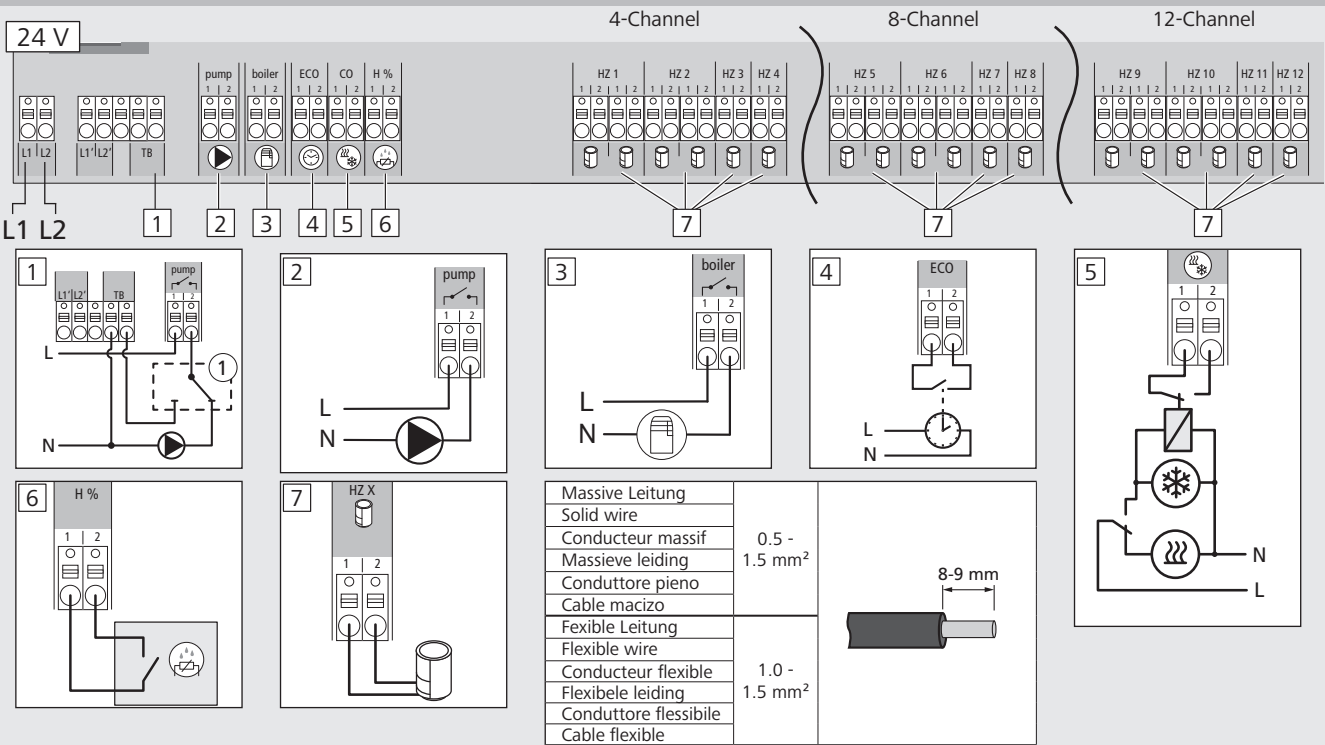

DEU ENG FRA NDL ITA ESP

| | | | | | | |
|---|---------------------|---------------------|---------------------------|----------------------|------------------------------|-----------------------------|
| 1 | Temperaturbegrenzer | Temperature limiter | Limiteur de température | Temperatuurbegrenzer | Limitatore di temperatura | Limitador de la temperatura |
| 2 | Pumpe | Pump | Pompe | Pomp | Pompa | Bomba |
| 3 | Kessel | Boiler | Chaudière | Ketel | Caldaia | Caldera |
| 4 | ECO | ECO | ECO | ECO | ECO | ECO |
| 5 | Change Over | Change over | Change-over | Change Over | Change Over | Change Over (conmutación) |
| 6 | Taupunktensor | Dew point sensor | Capteur du point de rosée | Dauwpuntsensor | Sensore del punto di rugiada | Sensor del punto de rocío |
| 7 | Stellantriebe | Actuators | Actionneurs | Stelaandrijvingen | Attuatori | Mandos de accionamiento |

► Anschluss System Bus / Connection of System Bus / Raccordement System Bus / Aansluiting System Bus / Collegamento System Bus / Conexión System Bus

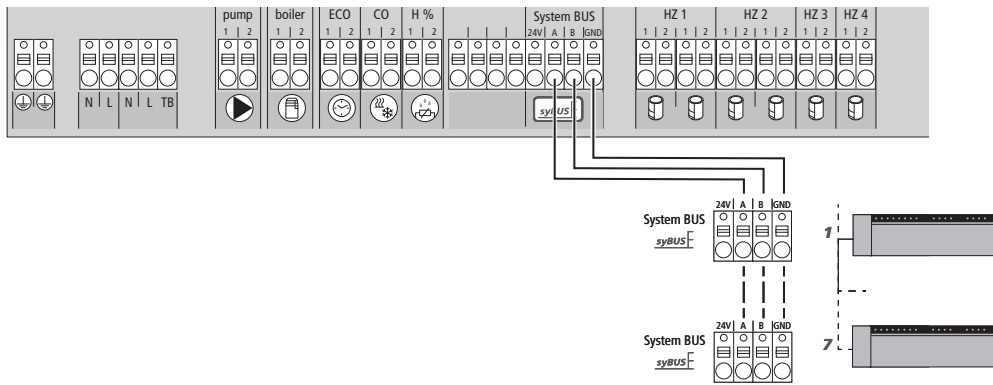

► Installation / Installatie / Installazione / Instalación

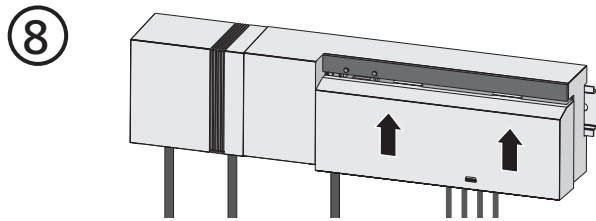
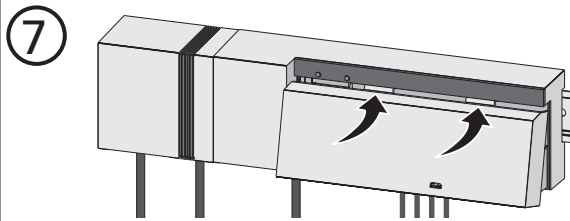

RDF 642x2-00

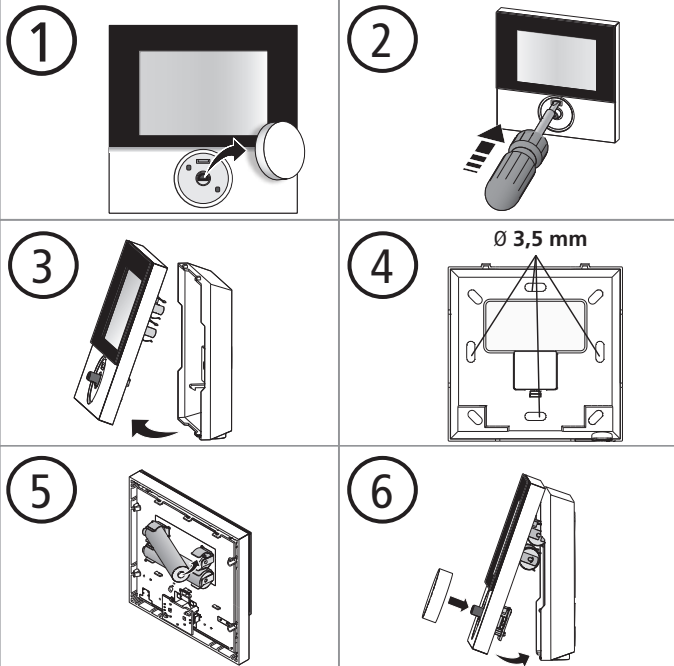

RF 642x2-22

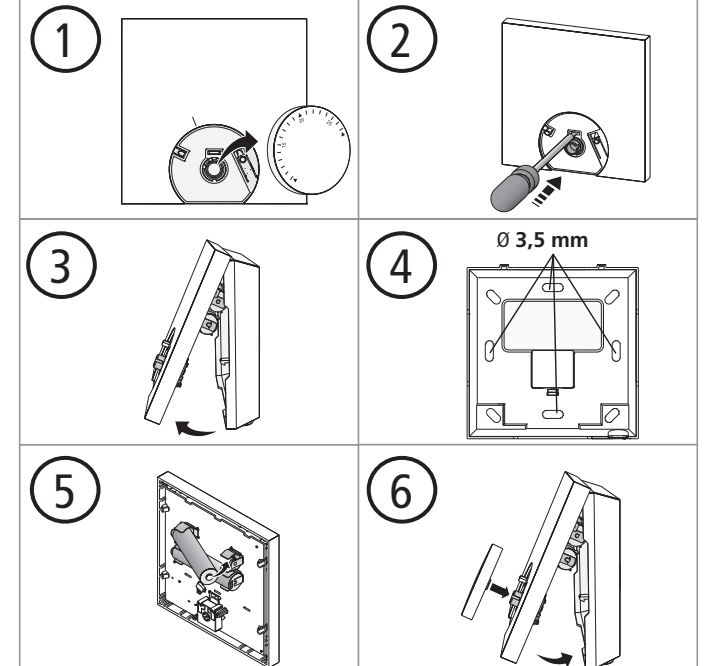

RSF 64202-00

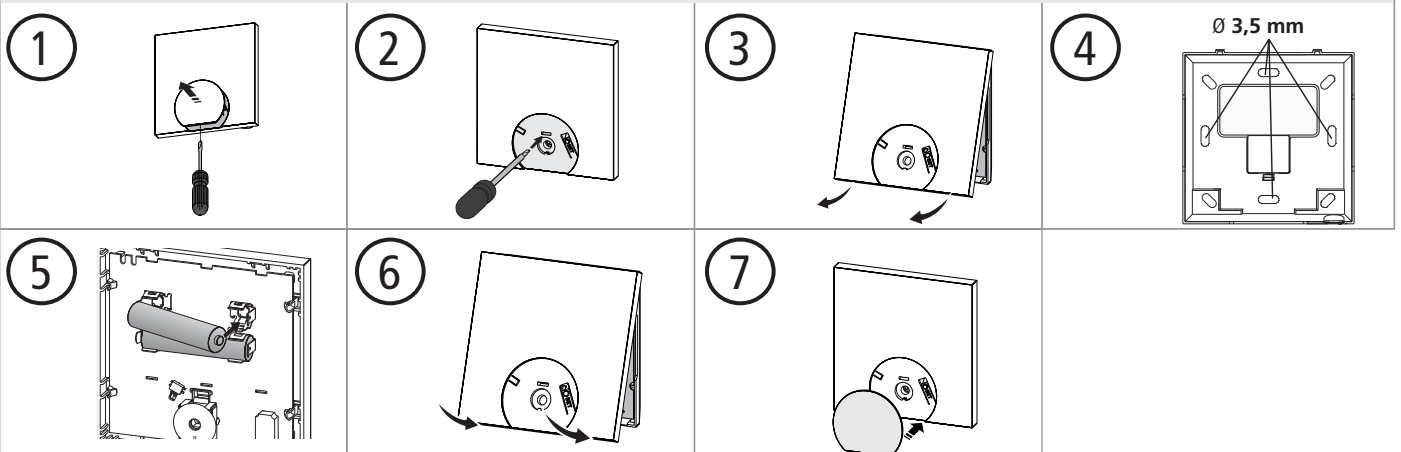

► **Erstinbetriebnahme / First commissioning / Première mise en Service / Eerste inbedrijfstelling / Prima messa in servizio / Puesta en funcionamiento por primera vez**

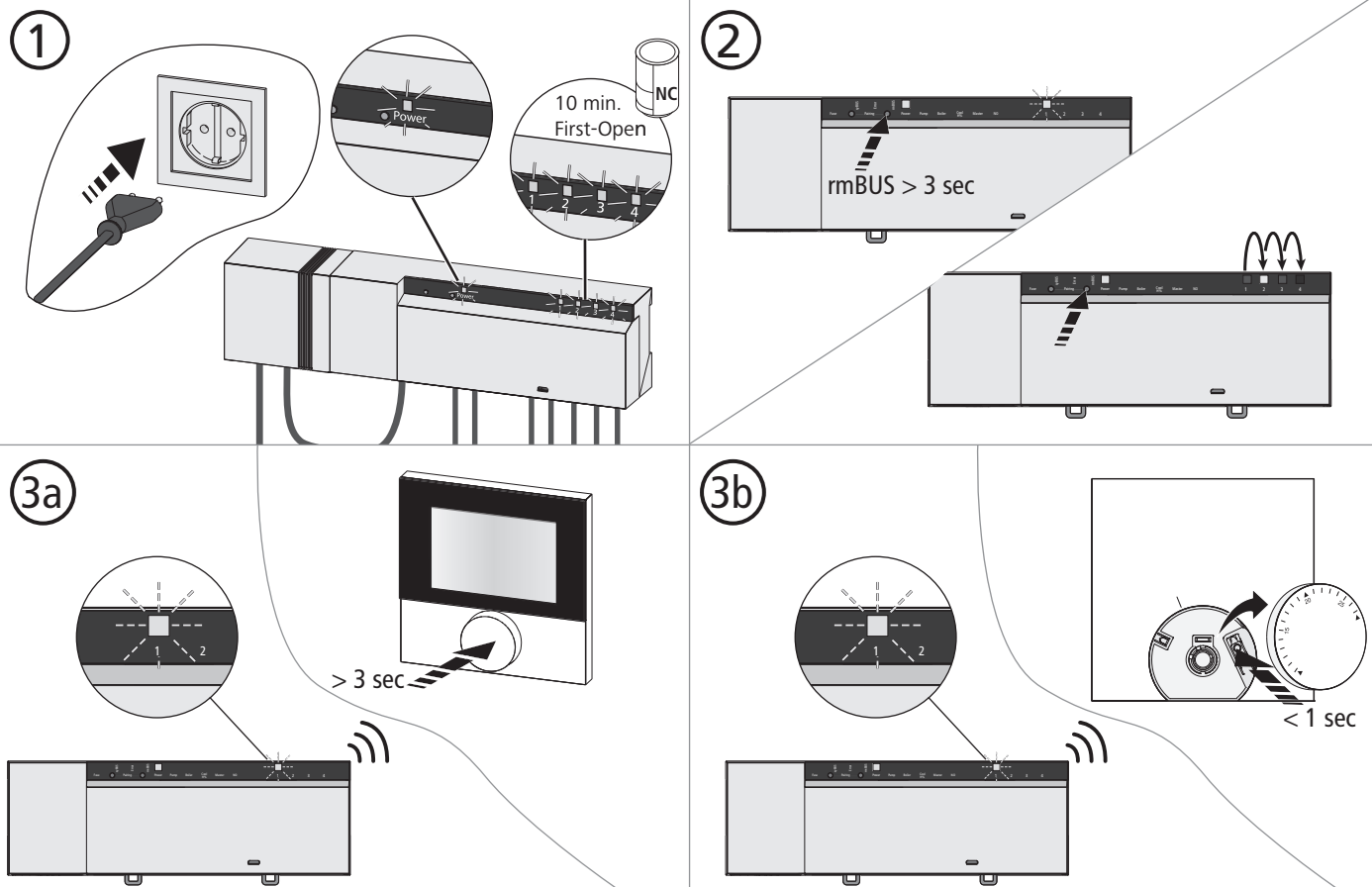

► **Anschlüsse / Connections / Connecteurs / Aansluitingen / Collegamenti / Conexiones**

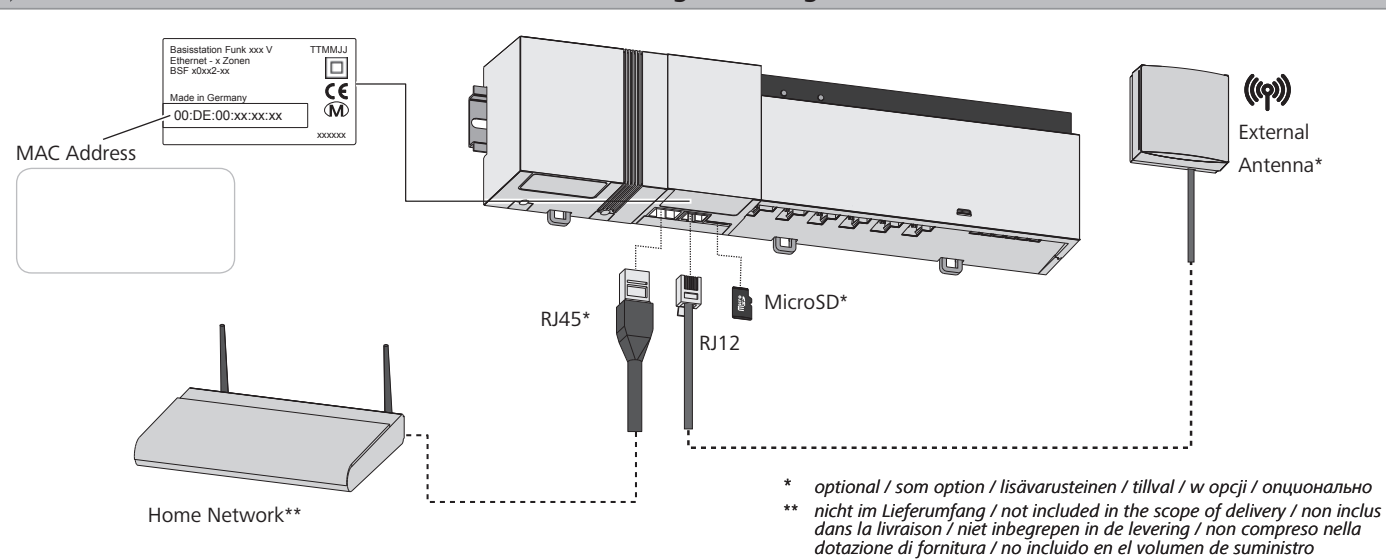

► **Bedienungsanleitung / Operating instructions / Mode d'emploi / Operatie instructies / Istruzioni per l'uso / Manual del usuario**



www.ezr-home.de

